

TECHNICAL DATA 589578102

LAMP INFO	
Description:	WL FONT S WH 3W
Mark:	10002 WL Wall Lamp
Reference:	589578102
Range:	58956 FONT
Code EAN:	8421797895785
Measures (mm):	0110-0110-0387
Weight (kg):	0.35

Lampholder/Watts:	LED 3W	CCT:	3000K	Switch:	Rocker switch
Bulb included:	Yes - CREE	Lm:	145	USB_C:	No
Class:	Class II	Effi LS:	G	Shade:	No
IP:	20	CRI:	80,00	Dimmable:	No
Driver inc.:	Yes	Lamp Power:	3,50W		
Voltage/Frequence:	230V - 50Hz	Applied Standard:	CE / LVD		

PACKAGING DETAILS

	Individual Box	Outer Box	Master Box
Type:	MDC - BROWN PRINTED	MDC - MARRON / BROWN	
Units:	1.00	4.00	0.00
Measures:	0155-0115-0225	0330-0250-0245	
Gross Weight (kg):	0.60	2.90	
CTN 40':	11.082,00		

OBSERVATIONS

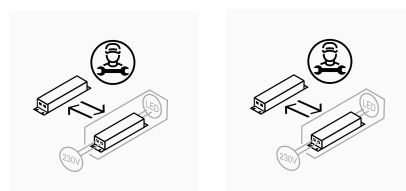

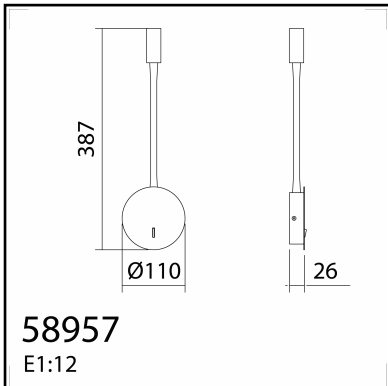

TECHNICAL DATA 589579102

LAMP INFO	
Description:	WL FONT S BK 3W
Mark:	10002 WL Wall Lamp
Reference:	589579102
Range:	58956 FONT
Code EAN:	8421797895792
Measures (mm):	0110-0110-0387
Weight (kg):	0.35

Lampholder/Watts:	LED 3W	CCT:	3000K	Switch:	Rocker switch
Bulb included:	Yes - CREE	Lm:	145	USB_C:	No
Class:	Class II	Effi LS:	G	Shade:	No
IP:	20	CRI:	80,00	Dimmable:	No
Driver inc.:	Yes	Lamp Power:	3,50W		
Voltage/Frequence:	230V - 50Hz	Applied Standard:	CE / LVD		

PACKAGING DETAILS

	Individual Box	Outer Box	Master Box
Type:	MDC - BROWN PRINTED	MDC - MARRON / BROWN	
Units:	1.00	4.00	0.00
Measures:	0155-0115-0225	0330-0250-0245	
Gross Weight (kg):	0.60	2.90	
CTN 40':	11.082,00		

OBSERVATIONS

