

TECHNICAL DATA 589318104

LAMP INFO	
Description:	FL CIRCULAR WH 1xE27
Mark:	20000 FL Floor Lamp
Reference:	589318104
Range:	58931 CIRCULAR
Code EAN:	8421797893187
Measures (mm):	2400-0500-2050
Weight (kg):	-

Lampholder/Watts:	E27 LED max. 20W	CCT:	-	Switch:	Foot switch
Bulb included:	No	Lm:	-	USB_C:	No
Class:	Class II	Effi LS:	-	Shade:	Yes
IP:	20	CRI:	-	Dimmable:	No
Driver inc.:	No	Lamp Power:	-		
Voltage/Frequence:	230V - 50Hz	Applied Standard:	CE / LVD		

PACKAGING DETAILS

	Individual Box	Outer Box	Master Box
Type:	MDC - BROWN PRINTED		
Units:	1.00	0.00	0.00
Measures:	2064-0335-0070	_____	_____
Gross Weight (kg):	-	-	-
CTN 40':	1.157,00		

OBSERVATIONS

Base and shade box size / Medidas de las cajas de la base y la pantalla:

Base box / Caja de la base: 536x536x108mm.

Shade box / Caja de la pantalla: 546x546x317mm.

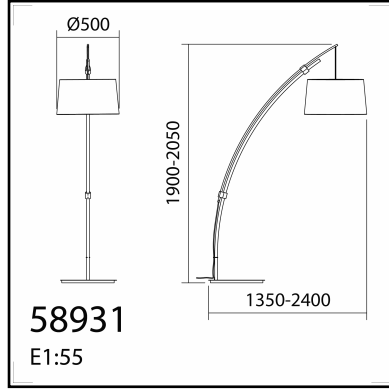

TECHNICAL DATA 589319104

LAMP INFO	
Description:	FL CIRCULAR BK 1xE27
Mark:	20000 FL Floor Lamp
Reference:	589319104
Range:	58931 CIRCULAR
Code EAN:	8421797893194
Measures (mm):	2400-0500-2050
Weight (kg):	-

Lampholder/Watts:	E27 LED max. 20W	CCT:	-	Switch:	Foot switch
Bulb included:	No	Lm:	-	USB_C:	No
Class:	Class II	Effi LS:	-	Shade:	Yes
IP:	20	CRI:	-	Dimmable:	No
Driver inc.:	No	Lamp Power:	-		
Voltage/Frequence:	230V - 50Hz	Applied Standard:	CE / LVD		

PACKAGING DETAILS

	Individual Box	Outer Box	Master Box
Type:	MDC - BROWN PRINTED		
Units:	1.00	0.00	0.00
Measures:	2064-0335-0070	_____	_____
Gross Weight (kg):	-	-	-
CTN 40':	1.157,00		

OBSERVATIONS

Base and shade box size / Medidas de las cajas de la base y la pantalla:

Base box / Caja de la base: 536x536x108mm.

Shade box / Caja de la pantalla: 546x546x317mm.