

58908
E1:40

TECHNICAL DATA 589088101

LAMP INFO

Description:	FL KAI WH E27
Mark:	20000 FL Floor Lamp
Reference:	589088101
Range:	58908 KAI
Code EAN:	8421797890889
Measures (mm):	0230-0240-1438
Weight (kg):	-

Lampholder/Watts:	E27 LED max.20W	CCT:	-	Switch:	Foot switch
Bulb included:	No	Lm:	-	USB_C:	No
Class:	Class II	Effi LS:	-	Shade:	No
IP:	20	CRI:	-	Dimmable:	No
Driver inc.:	No	Lamp Power:	-		
Voltage/Frequence:	230V - 50Hz	Applied Standard:	CE / LVD		

PACKAGING DETAILS

	Individual Box	Outer Box	Master Box
Type:	MDC - BROWN PRINTED	MDC - MARRON / BROWN	
Units:	1.00	4.00	0.00
Measures:	0390-0250-0150	0520-0415-0320	_____
Gross Weight (kg):	-	-	-
CTN 40':	3.243,00		

OBSERVATIONS

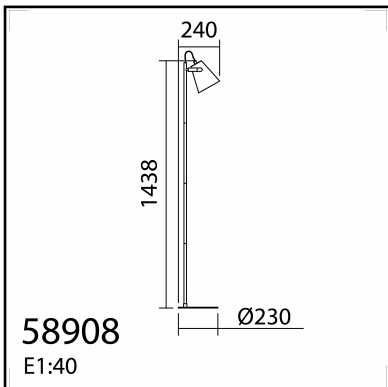

58908
E1:40

TECHNICAL DATA 589089101

LAMP INFO

Description:	FL KAI BK E27
Mark:	20000 FL Floor Lamp
Reference:	589089101
Range:	58908 KAI
Code EAN:	8421797890896
Measures (mm):	0230-0240-1438
Weight (kg):	-

Lampholder/Watts:	E27 LED max.20W	CCT:	-	Switch:	Foot switch
Bulb included:	No	Lm:	-	USB_C:	No
Class:	Class II	Effi LS:	-	Shade:	No
IP:	20	CRI:	-	Dimmable:	No
Driver inc.:	No	Lamp Power:	-		
Voltage/Frequence:	230V - 50Hz	Applied Standard:	CE / LVD		

PACKAGING DETAILS

	Individual Box	Outer Box	Master Box
Type:	MDC - BROWN PRINTED	MDC - MARRON / BROWN	
Units:	1.00	4.00	0.00
Measures:	0390-0250-0150	0520-0415-0320	_____
Gross Weight (kg):	-	-	-
CTN 40':	3.243,00		

OBSERVATIONS
