

TECHNICAL DATA 588936101

LAMP INFO	
Description:	CL CIAO MBss 1XE27 Ø24
Mark:	10001 CL Ceiling
Reference:	588936101
Range:	58890 CIAO
Code EAN:	8421797889364
Measures (mm):	0260-0260-0215
Weight (kg):	1.60

Lampholder/Watts:	E27 LED max.20W	CCT:	-	Switch:	No
Bulb included:	No	Lm:	-	USB_C:	No
Class:	Class I	Effi LS:	-	Shade:	No
IP:	20	CRI:	-	Dimmable:	No
Driver inc.:	No	Lamp Power:	-		
Voltage/Frequence:	230V - 50Hz	Applied Standard:	CE / LVD		

PACKAGING DETAILS			
	Individual Box	Outer Box	Master Box
Type:	MDC - BROWN PRINTED	MDC - MARRON / BROWN	
Units:	1.00	4.00	0.00
Measures:	0310-0310-0290	0640-0330-0620	
Gross Weight (kg):	2.33	9.30	-
CTN 40':	1.710,00		

OBSERVATIONS

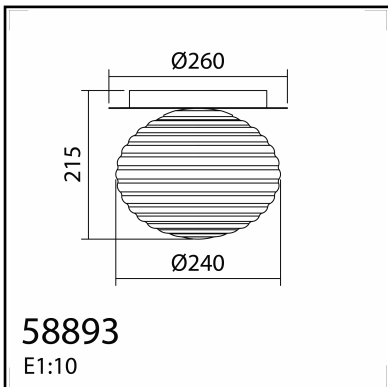

TECHNICAL DATA 588939101

LAMP INFO

Description:	CL CIAO BK 1XE27 Ø24
Mark:	10001 CL Ceiling
Reference:	588939101
Range:	58890 CIAO
Code EAN:	8421797889395
Measures (mm):	0260-0260-0215
Weight (kg):	1.60

Lampholder/Watts:	E27 LED max.20W	CCT:	-	Switch:	No
Bulb included:	No	Lm:	-	USB_C:	No
Class:	Class I	Effi LS:	-	Shade:	No
IP:	20	CRI:	-	Dimmable:	No
Driver inc.:	No	Lamp Power:	-		
Voltage/Frequence:	230V - 50Hz	Applied Standard:	CE / LVD		

PACKAGING DETAILS

	Individual Box	Outer Box	Master Box
Type:	MDC - BROWN PRINTED	MDC - MARRON / BROWN	
Units:	1.00	4.00	0.00
Measures:	0310-0310-0290	0640-0330-0620	
Gross Weight (kg):	2.33	9.30	-
CTN 40':	1.710,00		

OBSERVATIONS
