

TECHNICAL DATA 588778102

LAMP INFO	
Description:	WL FOCUS WH 3W 3000K + USB + BAT
Mark:	10002 WL Wall Lamp
Reference:	588778102
Range:	58877 FOCUS
Code EAN:	8421797887780
Measures (mm):	0095-0095-0069
Weight (kg):	-

Lampholder/Watts:	LED 3W	CCT:	3000K	Switch:	Push-button
Bulb included:	Yes - SMD	Lm:	120	USB_C:	Yes
Class:	Class III	Effi LS:	-	Shade:	No
IP:	20	CRI:	80,00	Dimmable:	No
Driver inc.:	Yes	Lamp Power:	3,00W		
Voltage/Frequence:	DC 5V - 1A	Applied Standard:	CE / LVD		

PACKAGING DETAILS			
	Individual Box	Outer Box	Master Box
Type:	MDC - BROWN PRINTED	MDC - MARRON / BROWN	
Units:	1.00	40.00	0.00
Measures:	0120-0120-0100	0500-0260-0525	_____
Gross Weight (kg):	0.11	4.40	-
CTN 40':	32.820,00		

OBSERVATIONS

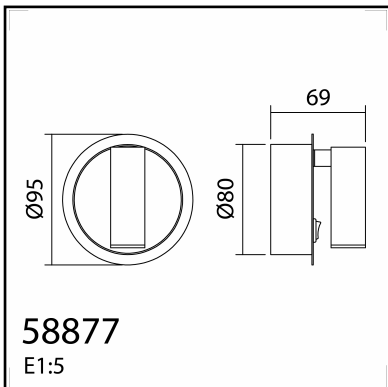
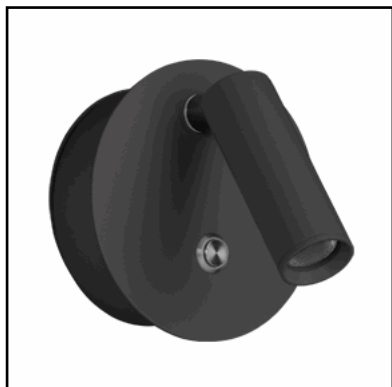

TECHNICAL DATA 588779102

LAMP INFO	
Description:	WL FOCUS BK 3W 3000K + USB + BAT
Mark:	10002 WL Wall Lamp
Reference:	588779102
Range:	58877 FOCUS
Code EAN:	8421797887797
Measures (mm):	0095-0095-0069
Weight (kg):	-

Lampholder/Watts:	LED 3W	CCT:	3000K	Switch:	Push-button
Bulb included:	Yes - SMD	Lm:	120	USB_C:	Yes
Class:	Class III	Effi LS:	-	Shade:	No
IP:	20	CRI:	80,00	Dimmable:	No
Driver inc.:	Yes	Lamp Power:	3,00W		
Voltage/Frequence:	DC 5V - 1A	Applied Standard:	CE / LVD		

PACKAGING DETAILS

	Individual Box	Outer Box	Master Box
Type:	MDC - BROWN PRINTED	MDC - MARRON / BROWN	
Units:	1.00	40.00	0.00
Measures:	0120-0120-0100	0500-0260-0525	_____
Gross Weight (kg):	0.11	4.40	-
CTN 40':	32.820,00		

OBSERVATIONS
