

TECHNICAL DATA 588688109

LAMP INFO	
Description:	FAN LISBOA WH Ø1065 DC30W 3A LED50W CCT+RC+DIM
Mark:	40000 FAN w/Light
Reference:	588688109
Range:	58868 LISBOA
Code EAN:	8421797886882
Measures (mm):	1065-1065-0485
Weight (kg):	8.80

Lampholder/Watts:	LED 50W	CCT:	3 steps CCT 3000K-4000K-6000K	Switch:	Remote Control
Bulb included:	Yes - SMD	Lm:	5500	USB_C:	No
Class:	Class I	Effi LS:	E	Shade:	No
IP:	20	CRI:	80,00	Dimmable:	Progressive 0-100% dimmer included
Driver inc.:	Yes	Lamp Power:	80,00W		
Voltage/Frequence:	230V - 50Hz	Applied Standard:	CE / LVD		

PACKAGING DETAILS

	Individual Box	Outer Box	Master Box
Type:	COLOR BOX		
Units:	1.00	0.00	0.00
Measures:	0550-0550-0305		
Gross Weight (kg):	10.00	-	-
CTN 40':	606,00		

OBSERVATIONS

Modes: 4 / Speed (Rpm): 90 / 170 / 188 / 240
Power (W): 6 / 13 / 24 / 30
Airflow (m3/h): 2500 / 4800 / 6600 / 7500
Room sizes: 15-30m2 / Number of blades: 3

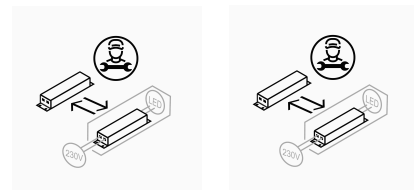

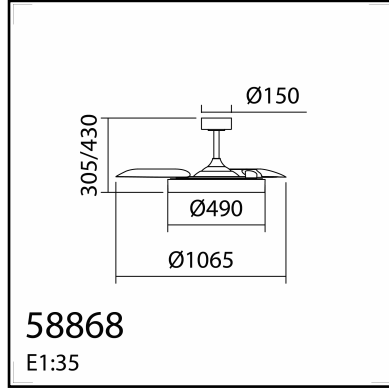

58868
E1:35

TECHNICAL DATA 58868709

LAMP INFO	
Description:	FAN LISBOA WH+WOOD Ø1065 DC30W LED50W CCT+DIM
Mark:	40000 FAN w/Light
Reference:	58868709
Range:	58868 LISBOA
Code EAN:	8421797886875
Measures (mm):	1065-1065-0485
Weight (kg):	8.80

Lampholder/Watts:	LED 50W	CCT:	3 steps CCT 3000K-4000K-6000K	Switch:	Remote Control
Bulb included:	Yes - SMD	Lm:	5500	USB_C:	No
Class:	Class I	Effi LS:	E	Shade:	No
IP:	20	CRI:	80,00	Dimmable:	Progressive 0-100% dimmer included
Driver inc.:	Yes	Lamp Power:	80,00W		
Voltage/Frequence:	230V - 50Hz	Applied Standard:	CE / LVD		

PACKAGING DETAILS

	Individual Box	Outer Box	Master Box
Type:	COLOR BOX		
Units:	1.00	0.00	0.00
Measures:	0550-0550-0305		
Gross Weight (kg):	10.00	-	-
CTN 40':	606,00		

OBSERVATIONS

Modes: 4 / Speed (Rpm): 90 / 170 / 188 / 240
Power (W): 6 / 13 / 24 / 30
Airflow (m3/h): 2500 / 4800 / 6600 / 7500
Room sizes: 15-30m2 / Number of blades: 3

