

**TECHNICAL DATA 580893504**

**LAMP INFO**

|                       |                           |               |  |
|-----------------------|---------------------------|---------------|--|
| <b>Description:</b>   | FL SAM SN E27+E14 pant WH |               |  |
| <b>Mark:</b>          | 20000                     | FL Floor Lamp |  |
| <b>Reference:</b>     | 580893504                 |               |  |
| <b>Range:</b>         | 58089                     | SAM           |  |
| <b>Code EAN:</b>      | 8421797808921             |               |  |
| <b>Measures (mm):</b> | 0280-0280-1700            |               |  |
| <b>Weight (kg):</b>   | 5.24                      |               |  |

|                           |                                  |                          |          |                  |               |
|---------------------------|----------------------------------|--------------------------|----------|------------------|---------------|
| <b>Lampholder/Watts:</b>  | E27 LED max.20W + E14 LED max.9W | <b>CCT:</b>              | -        | <b>Switch:</b>   | Toggle switch |
| <b>Bulb included:</b>     | Yes                              | <b>Lm:</b>               | -        | <b>USB_C:</b>    | No            |
| <b>Class:</b>             | Class II                         | <b>Effi LS:</b>          | -        | <b>Shade:</b>    | Yes           |
| <b>IP:</b>                | 20                               | <b>CRI:</b>              | -        | <b>Dimmable:</b> | No            |
| <b>Driver inc.:</b>       | No                               | <b>Lamp Power:</b>       | -        |                  |               |
| <b>Voltage/Frequence:</b> | 230V - 50Hz                      | <b>Applied Standard:</b> | CE / LVD |                  |               |

**PACKAGING DETAILS**

|                           | Individual Box | Outer Box | Master Box |
|---------------------------|----------------|-----------|------------|
| <b>Type:</b>              |                |           |            |
| <b>Units:</b>             | 1.00           | 0.00      | 0.00       |
| <b>Measures:</b>          | 0550-0430-0340 | _____     | _____      |
| <b>Gross Weight (kg):</b> | 7.50           | -         | -          |
| <b>CTN 40°:</b>           | 696,00         |           |            |

**OBSERVATIONS**

---



---



---



---



---

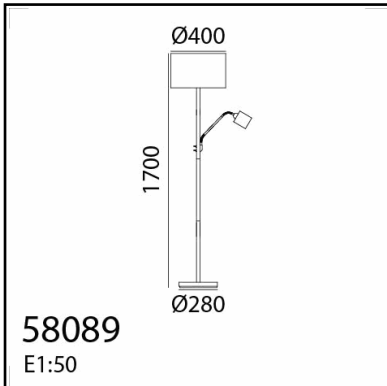

**TECHNICAL DATA 580894304**

| LAMP INFO      |                              |
|----------------|------------------------------|
| Description:   | FL SAM AB E27+E14 pant crema |
| Mark:          | 20000 FL Floor Lamp          |
| Reference:     | 580894304                    |
| Range:         | 58089 SAM                    |
| Code EAN:      | 8421797808945                |
| Measures (mm): | 0280-0280-1700               |
| Weight (kg):   | 5.24                         |

|                    |                                  |                   |          |           |               |
|--------------------|----------------------------------|-------------------|----------|-----------|---------------|
| Lampholder/Watts:  | E27 LED max.20W + E14 LED max.9W | CCT:              | -        | Switch:   | Toggle switch |
| Bulb included:     | Yes                              | Lm:               | -        | USB_C:    | No            |
| Class:             | Class II                         | Effi LS:          | -        | Shade:    | Yes           |
| IP:                | 20                               | CRI:              | -        | Dimmable: | No            |
| Driver inc.:       | No                               | Lamp Power:       | -        |           |               |
| Voltage/Frequence: | 230V - 50Hz                      | Applied Standard: | CE / LVD |           |               |

**PACKAGING DETAILS**

|                    | Individual Box | Outer Box | Master Box |
|--------------------|----------------|-----------|------------|
| Type:              |                |           |            |
| Units:             | 1.00           | 0.00      | 0.00       |
| Measures:          | 0550-0430-0340 | _____     | _____      |
| Gross Weight (kg): | 7.50           | -         | -          |
| CTN 40':           | 696,00         |           |            |

**OBSERVATIONS**

---



---



---



---



---

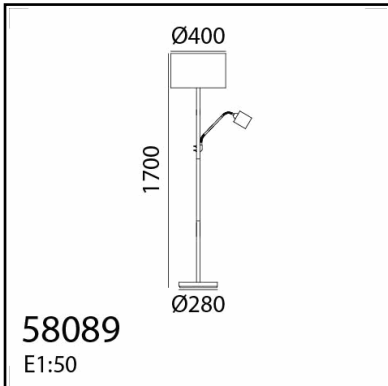

**TECHNICAL DATA 58089104**

**LAMP INFO**

|                       |                           |
|-----------------------|---------------------------|
| <b>Description:</b>   | FL SAM BK E27+E14 pant WH |
| <b>Mark:</b>          | 20000 FL Floor Lamp       |
| <b>Reference:</b>     | 58089104                  |
| <b>Range:</b>         | 58089 SAM                 |
| <b>Code EAN:</b>      | 8421797808990             |
| <b>Measures (mm):</b> | 0280-0280-1700            |
| <b>Weight (kg):</b>   | 5.24                      |

|                           |                                  |                          |          |                  |               |
|---------------------------|----------------------------------|--------------------------|----------|------------------|---------------|
| <b>Lampholder/Watts:</b>  | E27 LED max.20W + E14 LED max.9W | <b>CCT:</b>              | -        | <b>Switch:</b>   | Toggle switch |
| <b>Bulb included:</b>     | Yes                              | <b>Lm:</b>               | -        | <b>USB_C:</b>    | No            |
| <b>Class:</b>             | Class II                         | <b>Effi LS:</b>          | -        | <b>Shade:</b>    | Yes           |
| <b>IP:</b>                | 20                               | <b>CRI:</b>              | -        | <b>Dimmable:</b> | No            |
| <b>Driver inc.:</b>       | No                               | <b>Lamp Power:</b>       | -        |                  |               |
| <b>Voltage/Frequence:</b> | 230V - 50Hz                      | <b>Applied Standard:</b> | CE / LVD |                  |               |

**PACKAGING DETAILS**

|                           | Individual Box | Outer Box | Master Box |
|---------------------------|----------------|-----------|------------|
| <b>Type:</b>              |                |           |            |
| <b>Units:</b>             | 1.00           | 0.00      | 0.00       |
| <b>Measures:</b>          | 0550-0430-0340 | _____     | _____      |
| <b>Gross Weight (kg):</b> | 7.50           | -         | -          |
| <b>CTN 40°:</b>           | 696,00         |           |            |

**OBSERVATIONS**

---



---



---



---



---