

58087
E1:50

TECHNICAL DATA 580873502

LAMP INFO	
Description:	FL VEGA SN 40W+5W 3000k
Mark:	20000 FL Floor Lamp
Reference:	580873502
Range:	58087 VEGA
Code EAN:	8421797808723
Measures (mm):	0300-0300-1800
Weight (kg):	6.35

Lampholder/Watts:	LED 45W	CCT:	3000K	Switch:	Rotatory
Bulb included:	Yes - SMD	Lm:	4200	USB_C:	No
Class:	Class III	Effi LS:	E	Shade:	No
IP:	20	CRI:	83,00	Dimmable:	Progressive 0-100% dimmer included
Driver inc.:	Yes	Lamp Power:	45,00W		
Voltage/Frequence:	DC 24V - 1,5A	Applied Standard:	CE / LVD		

PACKAGING DETAILS

	Individual Box	Outer Box	Master Box
Type:	MDC - BROWN PRINTED		
Units:	1.00	0.00	0.00
Measures:	0370-0100-1035	_____	_____
Gross Weight (kg):	-	-	-
CTN 40':	1.462,00		

OBSERVATIONS

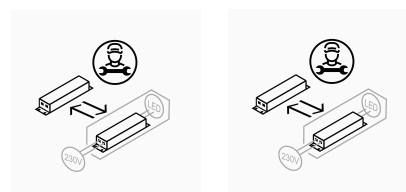

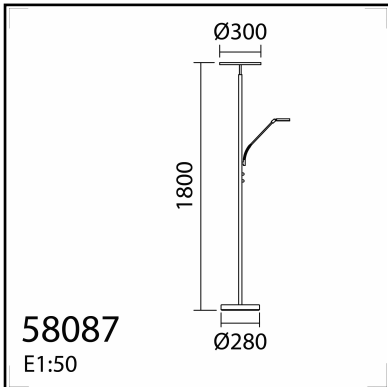

TECHNICAL DATA 580874302

LAMP INFO

Description:	FL VEGA AB 40W+5W 3000k
Mark:	20000 FL Floor Lamp
Reference:	580874302
Range:	58087 VEGA
Code EAN:	8421797808747
Measures (mm):	0300-0300-1800
Weight (kg):	6.35

Lampholder/Watts:	LED 45W	CCT:	3000K	Switch:	Rotatory
Bulb included:	Yes - SMD	Lm:	4200	USB_C:	No
Class:	Class III	Effi LS:	E	Shade:	No
IP:	20	CRI:	83,00	Dimmable:	Progressive 0-100% dimmer included
Driver inc.:	Yes	Lamp Power:	45,00W		
Voltage/Frequence:	DC 24V - 1,5A	Applied Standard:	CE / LVD		

PACKAGING DETAILS

	Individual Box	Outer Box	Master Box
Type:	MDC - BROWN PRINTED		
Units:	1.00	0.00	0.00
Measures:	0370-0100-1035		
Gross Weight (kg):	-	-	-
CTN 40':	1.462,00		

OBSERVATIONS

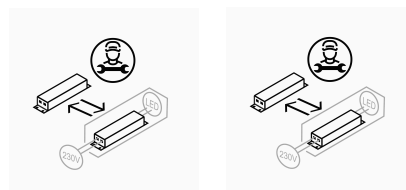

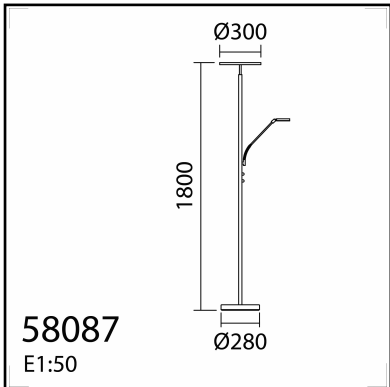

58087
E1:50

TECHNICAL DATA 580879102

LAMP INFO

Description:	FL VEGA BK 40W+5W 3000k
Mark:	20000 FL Floor Lamp
Reference:	580879102
Range:	58087 VEGA
Code EAN:	8421797808792
Measures (mm):	0300-0300-1800
Weight (kg):	6.35

Lampholder/Watts:	LED 45W	CCT:	3000K	Switch:	Rotatory
Bulb included:	Yes - SMD	Lm:	4200	USB_C:	No
Class:	Class III	Effi LS:	E	Shade:	No
IP:	20	CRI:	83,00	Dimmable:	Progressive 0-100% dimmer included
Driver inc.:	Yes	Lamp Power:	45,00W		
Voltage/Frequence:	DC 24V - 1,5A	Applied Standard:	CE / LVD		

PACKAGING DETAILS

	Individual Box	Outer Box	Master Box
Type:	MDC - BROWN PRINTED		
Units:	1.00	0.00	0.00
Measures:	0370-0100-1035	_____	_____
Gross Weight (kg):	-	-	-
CTN 40':	1.462,00		

OBSERVATIONS

