

**TECHNICAL DATA 580803502**

**LAMP INFO**

|                |                       |              |  |
|----------------|-----------------------|--------------|--|
| Description:   | WL TOIS cromo mate 8W |              |  |
| Mark:          | 10002                 | WL Wall Lamp |  |
| Reference:     | 580803502             |              |  |
| Range:         | 55347                 | TAIS         |  |
| Code EAN:      | 8421797808020         |              |  |
| Measures (mm): | 0123-0232-0076        |              |  |
| Weight (kg):   | 0.90                  |              |  |

|                    |             |                   |          |           |    |
|--------------------|-------------|-------------------|----------|-----------|----|
| Lampholder/Watts:  | LED 8W      | CCT:              | 3000K    | Switch:   | No |
| Bulb included:     | Yes - SMD   | Lm:               | 800      | USB_C:    | No |
| Class:             | Class II    | Effi LS:          | F        | Shade:    | No |
| IP:                | 20          | CRI:              | 82,00    | Dimmable: | No |
| Driver inc.:       | No          | Lamp Power:       | 8,00W    |           |    |
| Voltage/Frequence: | 230V - 50Hz | Applied Standard: | CE / LVD |           |    |

**PACKAGING DETAILS**

|                    | Individual Box      | Outer Box            | Master Box |
|--------------------|---------------------|----------------------|------------|
| Type:              | MDC - BROWN PRINTED | MDC - MARRON / BROWN |            |
| Units:             | 1.00                | 12.00                | 0.00       |
| Measures:          | 0180-0170-0275      | 0535-0380-0575       |            |
| Gross Weight (kg): | 1.10                | 13.60                | -          |
| CTN 40':           | 5.748,00            |                      |            |

**OBSERVATIONS**

---



---



---



---



---

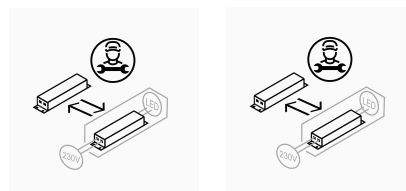

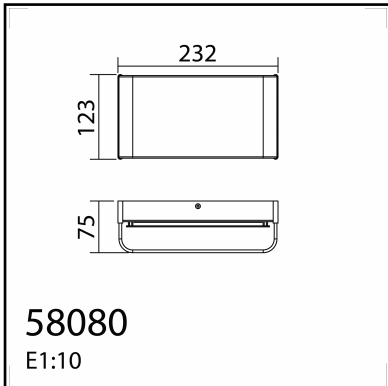
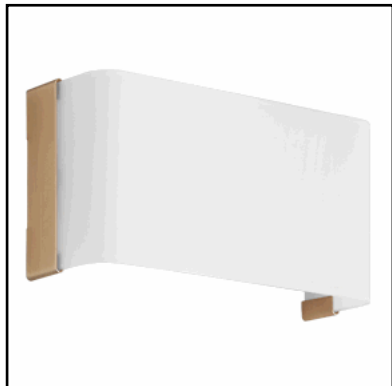

**TECHNICAL DATA 580806102**

**LAMP INFO**

|                |                       |              |  |
|----------------|-----------------------|--------------|--|
| Description:   | WL TOIS laton mate 8W |              |  |
| Mark:          | 10002                 | WL Wall Lamp |  |
| Reference:     | 580806102             |              |  |
| Range:         | 55347                 | TAIS         |  |
| Code EAN:      | 8421797808068         |              |  |
| Measures (mm): | 0123-0232-0076        |              |  |
| Weight (kg):   | 0.90                  |              |  |

|                    |             |                   |          |           |    |
|--------------------|-------------|-------------------|----------|-----------|----|
| Lampholder/Watts:  | LED 8W      | CCT:              | 3000K    | Switch:   | No |
| Bulb included:     | Yes - SMD   | Lm:               | 800      | USB_C:    | No |
| Class:             | Class II    | Effi LS:          | F        | Shade:    | No |
| IP:                | 20          | CRI:              | 86,00    | Dimmable: | No |
| Driver inc.:       | No          | Lamp Power:       | 8,00W    |           |    |
| Voltage/Frequence: | 230V - 50Hz | Applied Standard: | CE / LVD |           |    |

**PACKAGING DETAILS**

|                    | Individual Box      | Outer Box            | Master Box |
|--------------------|---------------------|----------------------|------------|
| Type:              | MDC - BROWN PRINTED | MDC - MARRON / BROWN |            |
| Units:             | 1.00                | 12.00                | 0.00       |
| Measures:          | 0180-0170-0275      | 0535-0380-0575       |            |
| Gross Weight (kg): | 1.10                | 13.60                | -          |
| CTN 40':           | 5.748,00            |                      |            |

**OBSERVATIONS**

---



---



---



---



---

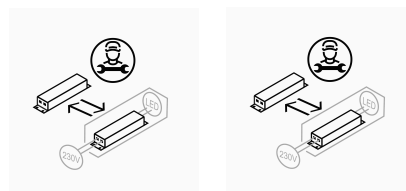

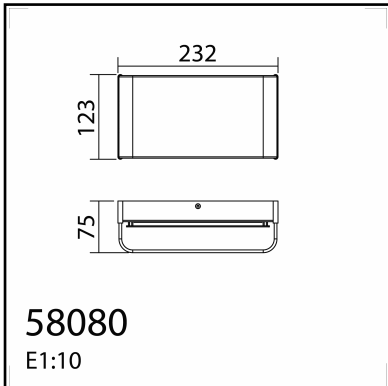
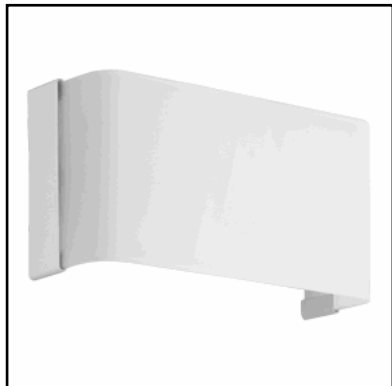

**TECHNICAL DATA 580808102**

| LAMP INFO      |                        |
|----------------|------------------------|
| Description:   | WL TOIS blanco mate 8W |
| Mark:          | 10002 WL Wall Lamp     |
| Reference:     | 580808102              |
| Range:         | 55347 TAIS             |
| Code EAN:      | 8421797808082          |
| Measures (mm): | 0123-0232-0076         |
| Weight (kg):   | 0.90                   |

|                    |             |                   |          |           |    |
|--------------------|-------------|-------------------|----------|-----------|----|
| Lampholder/Watts:  | LED 8W      | CCT:              | 3000K    | Switch:   | No |
| Bulb included:     | Yes - SMD   | Lm:               | 800      | USB_C:    | No |
| Class:             | Class II    | Effi LS:          | F        | Shade:    | No |
| IP:                | 20          | CRI:              | 86,00    | Dimmable: | No |
| Driver inc.:       | No          | Lamp Power:       | 8,00W    |           |    |
| Voltage/Frequence: | 230V - 50Hz | Applied Standard: | CE / LVD |           |    |

**PACKAGING DETAILS**

|                    | Individual Box      | Outer Box            | Master Box |
|--------------------|---------------------|----------------------|------------|
| Type:              | MDC - BROWN PRINTED | MDC - MARRON / BROWN |            |
| Units:             | 1.00                | 12.00                | 0.00       |
| Measures:          | 0180-0170-0275      | 0535-0380-0575       |            |
| Gross Weight (kg): | 1.10                | 13.60                |            |
| CTN 40':           | 5.748,00            |                      |            |

**OBSERVATIONS**

---



---



---



---



---

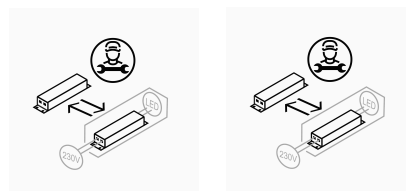

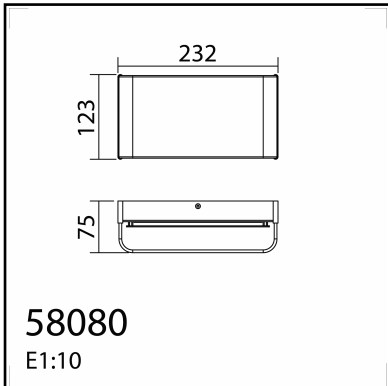

**TECHNICAL DATA 580809102**

**LAMP INFO**

|                |                       |              |  |
|----------------|-----------------------|--------------|--|
| Description:   | WL TOIS negro mate 8W |              |  |
| Mark:          | 10002                 | WL Wall Lamp |  |
| Reference:     | 580809102             |              |  |
| Range:         | 55347                 | TAIS         |  |
| Code EAN:      | 8421797808099         |              |  |
| Measures (mm): | 0123-0232-0076        |              |  |
| Weight (kg):   | 0.90                  |              |  |

|                    |             |                   |          |           |    |
|--------------------|-------------|-------------------|----------|-----------|----|
| Lampholder/Watts:  | LED 8W      | CCT:              | 3000K    | Switch:   | No |
| Bulb included:     | Yes - SMD   | Lm:               | 800      | USB_C:    | No |
| Class:             | Class II    | Effi LS:          | F        | Shade:    | No |
| IP:                | 20          | CRI:              | 86,00    | Dimmable: | No |
| Driver inc.:       | No          | Lamp Power:       | 8,00W    |           |    |
| Voltage/Frequence: | 230V - 50Hz | Applied Standard: | CE / LVD |           |    |

**PACKAGING DETAILS**

|                    | Individual Box      | Outer Box            | Master Box |
|--------------------|---------------------|----------------------|------------|
| Type:              | MDC - BROWN PRINTED | MDC - MARRON / BROWN |            |
| Units:             | 1.00                | 12.00                | 0.00       |
| Measures:          | 0180-0170-0275      | 0535-0380-0575       |            |
| Gross Weight (kg): | 1.10                | 13.60                |            |
| CTN 40':           | 5.748,00            |                      |            |

**OBSERVATIONS**

---



---



---



---



---

