

TECHNICAL DATA 58066103

LAMP INFO

Description:	WL FLOC latón mate E27 cristal Opal IP44
Mark:	10002 WL Wall Lamp
Reference:	580666103
Range:	58066 FLOC
Code EAN:	8421797806668
Measures (mm):	0220-0220-0184
Weight (kg):	0.92

Lampholder/Watts:	E27 LED max.20W	CCT:	-	Switch:	No
Bulb included:	No	Lm:	-	USB_C:	No
Class:	Class II	Effi LS:	-	Shade:	No
IP:	44	CRI:	-	Dimmable:	No
Driver inc.:	No	Lamp Power:	-		
Voltage/Frequence:	230V - 50Hz	Applied Standard:	CE / LVD		

PACKAGING DETAILS

	Individual Box	Outer Box	Master Box
Type:	MDC - BROWN PRINTED	MDC - MARRON / BROWN	
Units:	1.00	8.00	0.00
Measures:	0245-0245-0240	0510-0510-0500	_____
Gross Weight (kg):	1.36	11.88	-
CTN 40':	3.444,00		

OBSERVATIONS

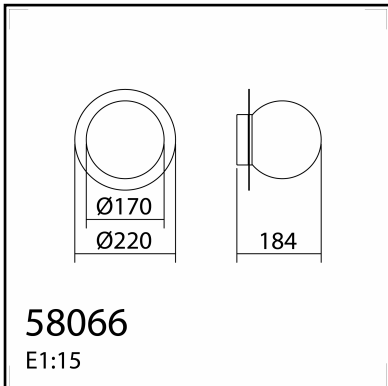
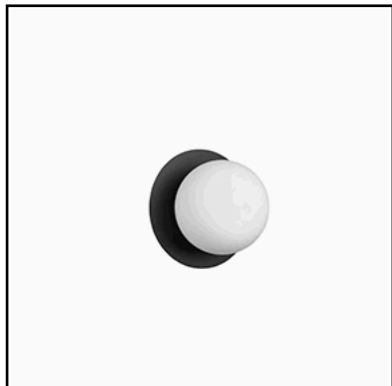

TECHNICAL DATA 580669103

LAMP INFO

Description:	WL FLOC negro mate E27 cristal Opal IP44
Mark:	10002 WL Wall Lamp
Reference:	580669103
Range:	58066 FLOC
Code EAN:	8421797806699
Measures (mm):	0220-0220-0184
Weight (kg):	0.92

Lampholder/Watts:	E27 LED max.20W	CCT:	-	Switch:	No
Bulb included:	No	Lm:	-	USB_C:	No
Class:	Class II	Effi LS:	-	Shade:	No
IP:	44	CRI:	-	Dimmable:	No
Driver inc.:	No	Lamp Power:	-		
Voltage/Frequence:	230V - 50Hz	Applied Standard:	CE / LVD		

PACKAGING DETAILS

	Individual Box	Outer Box	Master Box
Type:	MDC - BROWN PRINTED	MDC - MARRON / BROWN	
Units:	1.00	8.00	0.00
Measures:	0245-0245-0240	0510-0510-0500	_____
Gross Weight (kg):	1.36	11.88	-
CTN 40':	3.444,00		

OBSERVATIONS
