

TECHNICAL DATA 580533602

LAMP INFO

Description:	PL OSLO Niquel mate 16W cristal transp 3k
Mark:	10000 PD Pendant
Reference:	580533602
Range:	58050 OSLO
Code EAN:	8421797805326
Measures (mm):	0130-0130-2500
Weight (kg):	1.30

Lampholder/Watts:	LED 16W	CCT:	3000K	Switch:	No
Bulb included:	Yes - SMD	Lm:	1600	USB_C:	No
Class:	Class II	Effi LS:	F	Shade:	No
IP:	20	CRI:	80,00	Dimmable:	No
Driver inc.:	Yes	Lamp Power:	16,00W		
Voltage/Frequence:	230V - 50Hz	Applied Standard:	CE / LVD		

PACKAGING DETAILS

	Individual Box	Outer Box	Master Box
Type:	MDC - BROWN PRINTED	MDC - MARRON / BROWN	
Units:	1.00	8.00	0.00
Measures:	0160-0160-0720	0670-0340-0740	_____
Gross Weight (kg):	1.70	14.30	-
CTN 40':	2.657,00		

OBSERVATIONS

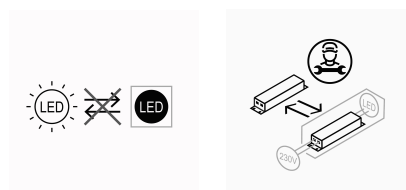

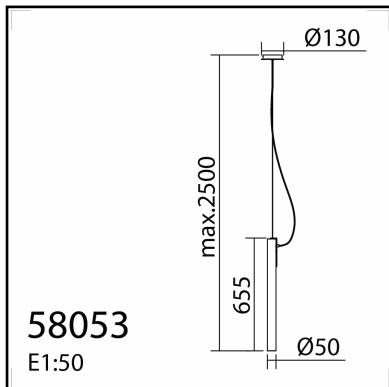

TECHNICAL DATA 580536102

LAMP INFO

Description:	PL OSLO Laton mate 16W cristal transp 3k
Mark:	10000 PD Pendant
Reference:	580536102
Range:	58050 OSLO
Code EAN:	8421797805371
Measures (mm):	0130-0130-2500
Weight (kg):	1.30

Lampholder/Watts:	LED 16W	CCT:	3000K	Switch:	No
Bulb included:	Yes - SMD	Lm:	1600	USB_C:	No
Class:	Class II	Effi LS:	F	Shade:	No
IP:	20	CRI:	80,00	Dimmable:	No
Driver inc.:	Yes	Lamp Power:	16,00W		
Voltage/Frequence:	230V - 50Hz	Applied Standard:	CE / LVD		

PACKAGING DETAILS

	Individual Box	Outer Box	Master Box
Type:	MDC - BROWN PRINTED	MDC - MARRON / BROWN	
Units:	1.00	8.00	0.00
Measures:	0160-0160-0720	0670-0340-0740	_____
Gross Weight (kg):	1.70	14.30	-
CTN 40':	2.657,00		

OBSERVATIONS

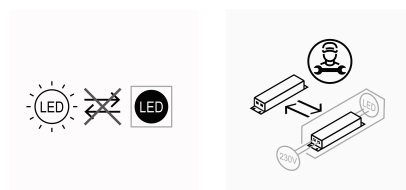

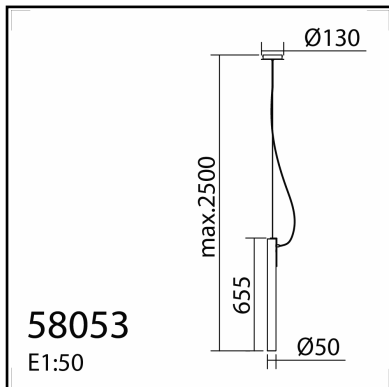

58053
E1:50

TECHNICAL DATA 580539102

LAMP INFO	
Description:	PL OSLO Negro mate 16W cristal transp 3k
Mark:	10000 PD Pendant
Reference:	580539102
Range:	58050 OSLO
Code EAN:	8421797805395
Measures (mm):	0130-0130-2500
Weight (kg):	1.30

Lampholder/Watts:	LED 16W	CCT:	3000K	Switch:	No
Bulb included:	Yes - SMD	Lm:	1600	USB_C:	No
Class:	Class II	Effi LS:	F	Shade:	No
IP:	20	CRI:	80,00	Dimmable:	No
Driver inc.:	Yes	Lamp Power:	16,00W		
Voltage/Frequence:	230V - 50Hz	Applied Standard:	CE / LVD		

PACKAGING DETAILS

	Individual Box	Outer Box	Master Box
Type:	MDC - BROWN PRINTED	MDC - MARRON / BROWN	
Units:	1.00	8.00	0.00
Measures:	0160-0160-0700	0670-0340-0740	_____
Gross Weight (kg):	1.70	14.30	-
CTN 40':	2.657,00		

OBSERVATIONS

