

TECHNICAL DATA 580513602

LAMP INFO

Description:	WL OSLO Niquel mate 8W cristal transp 3k
Mark:	10002 WL Wall Lamp
Reference:	580513602
Range:	58050 OSLO
Code EAN:	8421797805135
Measures (mm):	0350-0130-0080
Weight (kg):	0.80

Lampholder/Watts:	LED 8W	CCT:	3000K	Switch:	No
Bulb included:	Yes - SMD	Lm:	800	USB_C:	No
Class:	Class II	Effi LS:	F	Shade:	No
IP:	20	CRI:	80,00	Dimmable:	No
Driver inc.:	Yes	Lamp Power:	8,00W		
Voltage/Frequence:	230V - 50Hz	Applied Standard:	CE / LVD		

PACKAGING DETAILS

	Individual Box	Outer Box	Master Box
Type:	MDC - BROWN PRINTED	MDC - MARRON / BROWN	
Units:	1.00	12.00	0.00
Measures:	0170-0110-0405	0535-0470-0425	_____
Gross Weight (kg):	0.90	12.00	-
CTN 40':	6.288,00		

OBSERVATIONS

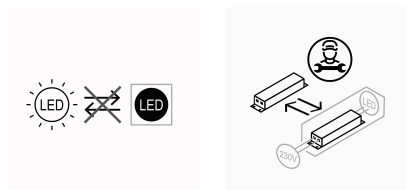

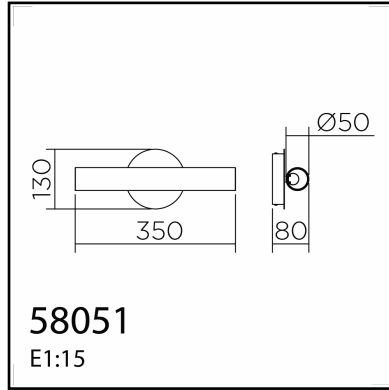
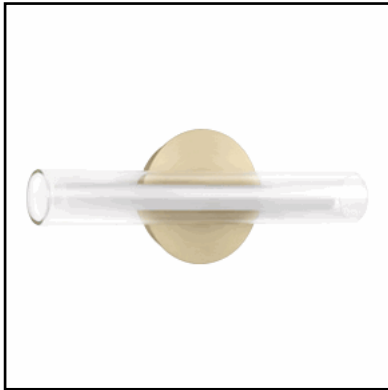

TECHNICAL DATA 580516102

LAMP INFO	
Description:	WL OSLO Laton mate 8W cristal transp 3k
Mark:	10002 WL Wall Lamp
Reference:	580516102
Range:	58050 OSLO
Code EAN:	8421797805173
Measures (mm):	0350-0130-0080
Weight (kg):	0.80

Lampholder/Watts:	LED 8W	CCT:	3000K	Switch:	No
Bulb included:	Yes - SMD	Lm:	800	USB_C:	No
Class:	Class II	Effi LS:	F	Shade:	No
IP:	20	CRI:	80,00	Dimmable:	No
Driver inc.:	Yes	Lamp Power:	8,00W		
Voltage/Frequence:	230V - 50Hz	Applied Standard:	CE / LVD		

PACKAGING DETAILS			
	Individual Box	Outer Box	Master Box
Type:	MDC - BROWN PRINTED	MDC - MARRON / BROWN	
Units:	1.00	12.00	0.00
Measures:	0170-0110-0405	0535-0470-0425	_____
Gross Weight (kg):	0.90	12.00	-
CTN 40':	6.288,00		

OBSERVATIONS

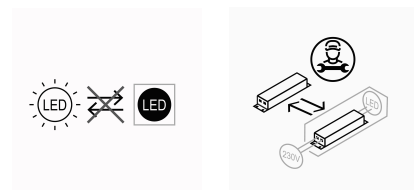

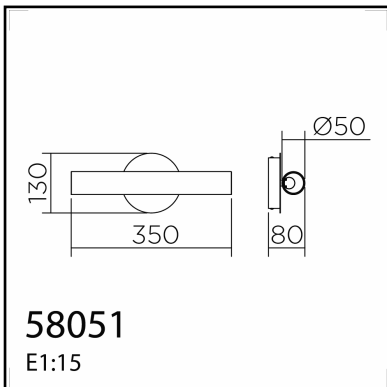
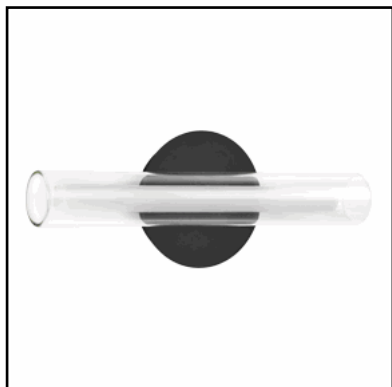

TECHNICAL DATA 580519102

LAMP INFO	
Description:	WL OSLO negro mate 8W cristal transp 3k
Mark:	10002 WL Wall Lamp
Reference:	580519102
Range:	58050 OSLO
Code EAN:	8421797805197
Measures (mm):	0350-0130-0080
Weight (kg):	0.80

Lampholder/Watts:	LED 8W	CCT:	3000K	Switch:	No
Bulb included:	Yes - SMD	Lm:	800	USB_C:	No
Class:	Class II	Effi LS:	F	Shade:	No
IP:	20	CRI:	80,00	Dimmable:	No
Driver inc.:	Yes	Lamp Power:	8,00W		
Voltage/Frequence:	230V - 50Hz	Applied Standard:	CE / LVD		

PACKAGING DETAILS

	Individual Box	Outer Box	Master Box
Type:	MDC - BROWN PRINTED	MDC - MARRON / BROWN	
Units:	1.00	12.00	0.00
Measures:	0170-0110-0405	0535-0470-0425	_____
Gross Weight (kg):	0.90	12.00	-
CTN 40':	6.288,00		

OBSERVATIONS

