

TECHNICAL DATA 580215501

LAMP INFO	
Description:	PL DAVID natural Ø35cm 1xE27
Mark:	10000 PD Pendant
Reference:	580215501
Range:	58021 DAVID
Code EAN:	8421797802158
Measures (mm):	0350-0350-1290
Weight (kg):	0.42

Lampholder/Watts:	E27 LED max.20W	CCT:	-	Switch:	No
Bulb included:	No	Lm:	-	USB_C:	No
Class:	Class I	Effi LS:	-	Shade:	No
IP:	20	CRI:	-	Dimmable:	No
Driver inc.:	No	Lamp Power:	-		
Voltage/Frequence:	230V - 50Hz	Applied Standard:	CE / LVD		

PACKAGING DETAILS			
	Individual Box	Outer Box	Master Box
Type:	MDC - BROWN PRINTED		
Units:	1.00	0.00	0.00
Measures:	0370-0240-0370	_____	_____
Gross Weight (kg):	0.98	-	-
CTN 40':	1.704,00		

OBSERVATIONS

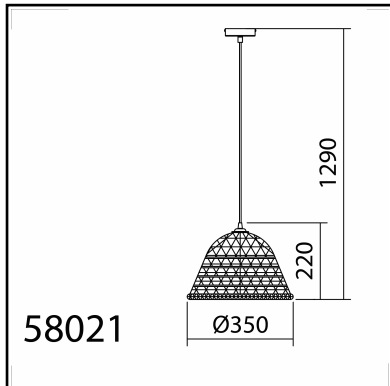

TECHNICAL DATA 580219101

LAMP INFO

Description:	PL DAVID negro Ø35cm 1xE27
Mark:	10000 PD Pendant
Reference:	580219101
Range:	58021 DAVID
Code EAN:	8421797802196
Measures (mm):	0350-0350-1290
Weight (kg):	0.42

Lampholder/Watts:	E27 LED max.20W	CCT:	-	Switch:	No
Bulb included:	No	Lm:	-	USB_C:	No
Class:	Class I	Effi LS:	-	Shade:	No
IP:	20	CRI:	-	Dimmable:	No
Driver inc.:	No	Lamp Power:	-		
Voltage/Frequence:	230V - 50Hz	Applied Standard:	CE / LVD		

PACKAGING DETAILS

	Individual Box	Outer Box	Master Box
Type:	MDC - BROWN PRINTED		
Units:	1.00	0.00	0.00
Measures:	0370-0240-0370	_____	_____
Gross Weight (kg):	0.98	-	-
CTN 40':	1.704,00		

OBSERVATIONS

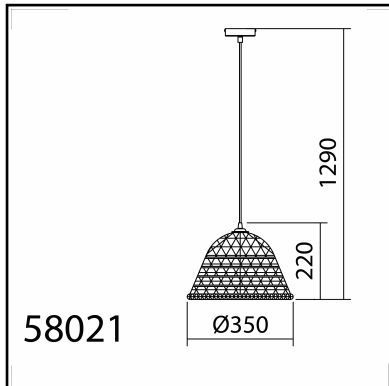

58021

TECHNICAL DATA 580218101

LAMP INFO

Description:	PL DAVID blanco Ø35cm 1xE27
Mark:	10000 PD Pendant
Reference:	580218101
Range:	58021 DAVID
Code EAN:	8421797802189
Measures (mm):	0350-0350-1290
Weight (kg):	0.42

Lampholder/Watts:	E27 LED max.20W	CCT:	-	Switch:	No
Bulb included:	No	Lm:	-	USB_C:	No
Class:	Class I	Effi LS:	-	Shade:	No
IP:	20	CRI:	-	Dimmable:	No
Driver inc.:	No	Lamp Power:	-		
Voltage/Frequence:	230V - 50Hz	Applied Standard:	CE / LVD		

PACKAGING DETAILS

	Individual Box	Outer Box	Master Box
Type:	MDC - BROWN PRINTED		
Units:	1.00	0.00	0.00
Measures:	0370-0240-0370	_____	_____
Gross Weight (kg):	0.98	-	-
CTN 40':	1.704,00		

OBSERVATIONS
