

TECHNICAL DATA 579303501

LAMP INFO	
Description:	FL SARA cromo mate 2xE27 +1xE14
Mark:	20000 FL Floor Lamp
Reference:	579303501
Range:	57930 SARA
Code EAN:	8421797793036
Measures (mm):	0280-0280-1800
Weight (kg):	7.18

Lampholder/Watts:	2xE27 LED max.20W + E14 LED max.9W	CCT:	-	Switch:	Toggle switch
Bulb included:	No	Lm:	-	USB_C:	No
Class:	Class II	Effi LS:	-	Shade:	No
IP:	20	CRI:	-	Dimmable:	No
Driver inc.:	No	Lamp Power:	-		
Voltage/Frequence:	230V - 50Hz	Applied Standard:	CE / LVD		

PACKAGING DETAILS			
	Individual Box	Outer Box	Master Box
Type:	MDC-MARRON / BROWN		
Units:	1.00	0.00	0.00
Measures:	0360-0140-1025	_____	_____
Gross Weight (kg):	10.24	-	-
CTN 40°:	1.084,00		

OBSERVATIONS

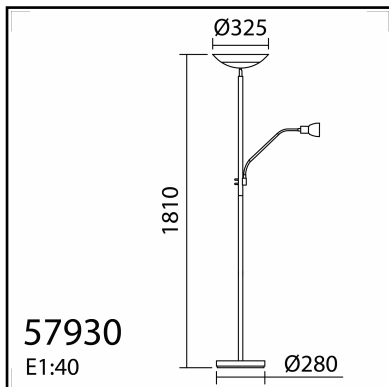

TECHNICAL DATA 579304301

LAMP INFO	
Description:	FL SARA MEDALLA 2xE27 +1xE14
Mark:	20000 FL Floor Lamp
Reference:	579304301
Range:	57930 SARA
Code EAN:	8421797793043
Measures (mm):	0280-0280-1800
Weight (kg):	7.18

Lampholder/Watts:	2xE27 LED max.20W + E14 LED max.9W	CCT:	-	Switch:	Toggle switch
Bulb included:	No	Lm:	-	USB_C:	No
Class:	Class II	Effi LS:	-	Shade:	No
IP:	20	CRI:	-	Dimmable:	No
Driver inc.:	No	Lamp Power:	-		
Voltage/Frequence:	230V - 50Hz	Applied Standard:	CE / LVD		

PACKAGING DETAILS			
	Individual Box	Outer Box	Master Box
Type:	MDC-MARRON / BROWN		
Units:	1.00	0.00	0.00
Measures:	0360-0140-1025	_____	_____
Gross Weight (kg):	10.24	-	-
CTN 40°:	1.084,00		

OBSERVATIONS
