

57808  
E1:25

**TECHNICAL DATA 578086101**

| LAMP INFO      |                                 |
|----------------|---------------------------------|
| Description:   | SF RONDO LATÓN MATE 3xE27 Ø15cm |
| Mark:          | 10000 PD Pendant                |
| Reference:     | 578086101                       |
| Range:         | 57804 RONDO                     |
| Code EAN:      | 8421797780869                   |
| Measures (mm): | 0305-0290-0525                  |
| Weight (kg):   | 1.51                            |

|                    |                   |                   |          |           |    |
|--------------------|-------------------|-------------------|----------|-----------|----|
| Lampholder/Watts:  | 3xE27 LED max.20W | CCT:              | -        | Switch:   | No |
| Bulb included:     | No                | Lm:               | -        | USB_C:    | No |
| Class:             | Class I           | Effi LS:          | -        | Shade:    | No |
| IP:                | 20                | CRI:              | -        | Dimmable: | No |
| Driver inc.:       | No                | Lamp Power:       | -        |           |    |
| Voltage/Frequence: | 230V - 50Hz       | Applied Standard: | CE / LVD |           |    |

**PACKAGING DETAILS**

|                    | Individual Box      | Outer Box            | Master Box |
|--------------------|---------------------|----------------------|------------|
| Type:              | MDC - BROWN PRINTED | MDC - MARRON / BROWN |            |
| Units:             | 1.00                | 0.00                 | 0.00       |
| Measures:          | 0520-0170-0330      | _____                | _____      |
| Gross Weight (kg): | 1.91                | -                    | -          |
| CTN 40°:           | 1.919,00            |                      |            |

**OBSERVATIONS**

---



---



---



---



---

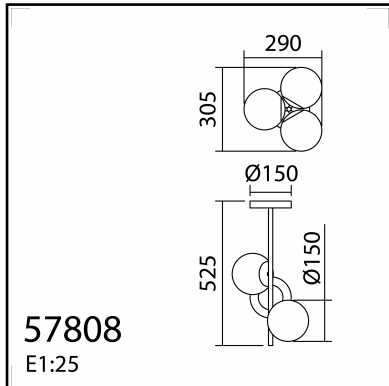
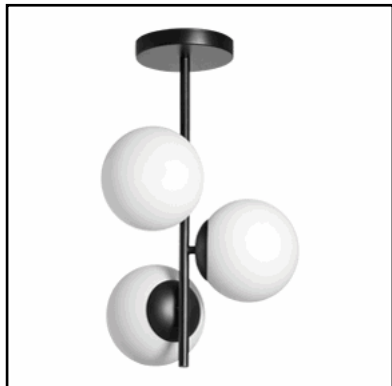

57808  
E1:25

**TECHNICAL DATA 578089101**

**LAMP INFO**

|                |                                 |
|----------------|---------------------------------|
| Description:   | SF RONDO NEGRO MATE 3xE27 Ø15cm |
| Mark:          | 10000 PD Pendant                |
| Reference:     | 578089101                       |
| Range:         | 57804 RONDO                     |
| Code EAN:      | 8421797780890                   |
| Measures (mm): | 0305-0290-0525                  |
| Weight (kg):   | 1.51                            |

|                    |                   |                   |          |           |    |
|--------------------|-------------------|-------------------|----------|-----------|----|
| Lampholder/Watts:  | 3xE27 LED max.20W | CCT:              | -        | Switch:   | No |
| Bulb included:     | No                | Lm:               | -        | USB_C:    | No |
| Class:             | Class I           | Effi LS:          | -        | Shade:    | No |
| IP:                | 20                | CRI:              | -        | Dimmable: | No |
| Driver inc.:       | No                | Lamp Power:       | -        |           |    |
| Voltage/Frequence: | 230V - 50Hz       | Applied Standard: | CE / LVD |           |    |

**PACKAGING DETAILS**

|                    | Individual Box      | Outer Box            | Master Box |
|--------------------|---------------------|----------------------|------------|
| Type:              | MDC - BROWN PRINTED | MDC - MARRON / BROWN |            |
| Units:             | 1.00                | 0.00                 | 0.00       |
| Measures:          | 0520-0170-0330      |                      |            |
| Gross Weight (kg): | 1.91                | -                    | -          |
| CTN 40°:           | 1.919,00            |                      |            |

**OBSERVATIONS**

---



---



---



---



---