

TECHNICAL DATA 577958101

LAMP INFO	
Description:	RL CIGNO blanco mate 1xE27
Mark:	20000 FL Floor Lamp
Reference:	577958101
Range:	57795 CIGNO
Code EAN:	8421797779580
Measures (mm):	1680-0220-0220
Weight (kg):	2.50

Lampholder/Watts:	E27 LED max.20W	CCT:	-	Switch:	Foot switch
Bulb included:	No	Lm:	-	USB_C:	No
Class:	Class II	Effi LS:	-	Shade:	No
IP:	20	CRI:	-	Dimmable:	No
Driver inc.:	No	Lamp Power:	-		
Voltage/Frequence:	230V - 50Hz	Applied Standard:	CE / LVD		

PACKAGING DETAILS			
	Individual Box	Outer Box	Master Box
Type:	MDC-MARRON / BROWN	MDC - MARRON / BROWN (c)	
Units:	1.00	2.00	0.00
Measures:	0410-0260-0195	0380-0260-0430	
Gross Weight (kg):	3.00	6.50	-
CTN 40°:	2.636,00		

OBSERVATIONS
180cm cable
Modificació: 01/02/23

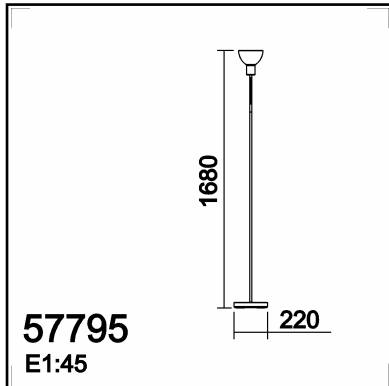

TECHNICAL DATA 577959101

LAMP INFO	
Description:	RL CIGNO negro mate 1xE27
Mark:	20000 FL Floor Lamp
Reference:	577959101
Range:	57795 CIGNO
Code EAN:	8421797779597
Measures (mm):	1680-0220-0220
Weight (kg):	2.50

Lampholder/Watts:	E27 LED max.20W	CCT:	-	Switch:	Foot switch
Bulb included:	No	Lm:	-	USB_C:	No
Class:	Class II	Effi LS:	-	Shade:	No
IP:	20	CRI:	-	Dimmable:	No
Driver inc.:	No	Lamp Power:	-		
Voltage/Frequence:	230V - 50Hz	Applied Standard:	CE / LVD		

PACKAGING DETAILS

	Individual Box	Outer Box	Master Box
Type:	MDC-MARRON / BROWN	MDC - MARRON / BROWN (c)	
Units:	1.00	2.00	0.00
Measures:	0410-0260-0195	0380-0260-0430	_____
Gross Weight (kg):	3.00	6.50	-
CTN 40':	2.636,00		

OBSERVATIONS

180cm cable

Modificació: 01/02/23