

TECHNICAL DATA 577578109

LAMP INFO	
Description:	WL CHELSEA LED 3W blanco mate 3k + USB
Mark:	10002 WL Wall Lamp
Reference:	577578109
Range:	57757 CHELSEA
Code EAN:	842179775773
Measures (mm):	0180-0060-0146
Weight (kg):	0.45

Lampholder/Watts:	LED 3W	CCT:	3000K	Switch:	No
Bulb included:	Yes - CREE	Lm:	160	USB_C:	Yes
Class:	Class II	Effi LS:	G	Shade:	No
IP:	20	CRI:	90,00	Dimmable:	No
Driver inc.:	Yes	Lamp Power:	3,00W		
Voltage/Frequence:	230V - 50Hz	Applied Standard:	CE / LVD		

PACKAGING DETAILS

	Individual Box	Outer Box	Master Box
Type:	MDC - BROWN PRINTED	MDC - MARRON / BROWN	
Units:	1.00	16.00	0.00
Measures:	0205-0100-0080	0345-0215-0430	
Gross Weight (kg):	0.57	9.32	-
CTN 40':	28.091,00		

OBSERVATIONS

USB-C socket 5VDC 2A

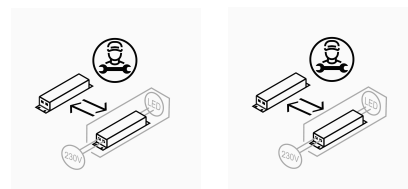

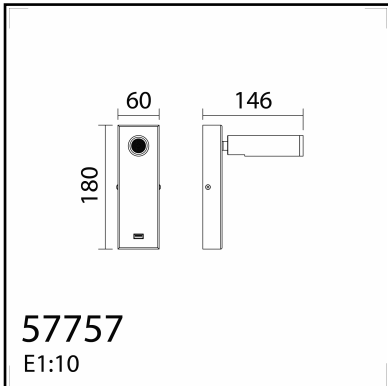

TECHNICAL DATA 577579109

LAMP INFO	
Description:	WL CHELSEA LED 3W negro mate 3k + USB
Mark:	10002 WL Wall Lamp
Reference:	577579109
Range:	57757 CHELSEA
Code EAN:	842179775742
Measures (mm):	0180-0060-0146
Weight (kg):	0.45

Lampholder/Watts:	LED 3W	CCT:	3000K	Switch:	No
Bulb included:	Yes - CREE	Lm:	160	USB_C:	Yes
Class:	Class II	Effi LS:	G	Shade:	No
IP:	20	CRI:	90,00	Dimmable:	No
Driver inc.:	Yes	Lamp Power:	3,00W		
Voltage/Frequence:	230V - 50Hz	Applied Standard:	CE / LVD		

PACKAGING DETAILS

	Individual Box	Outer Box	Master Box
Type:	MDC - BROWN PRINTED	MDC - MARRON / BROWN	
Units:	1.00	16.00	0.00
Measures:	0205-0100-0080	0345-0215-0430	
Gross Weight (kg):	0.57	9.32	-
CTN 40':	28.091,00		

OBSERVATIONS

USB-C socket 5VDC 2A

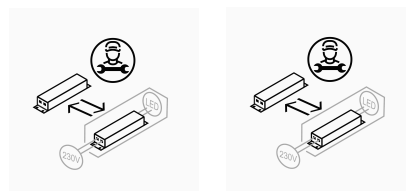

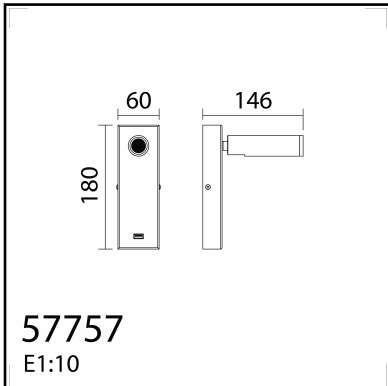

TECHNICAL DATA 577573609

LAMP INFO	
Description:	WL CHELSEA LED 3W níquel mate 3k + USB
Mark:	10002 WL Wall Lamp
Reference:	577573609
Range:	57757 CHELSEA
Code EAN:	842179775735
Measures (mm):	0180-0060-0146
Weight (kg):	0.45

Lampholder/Watts:	LED 3W	CCT:	3000K	Switch:	No
Bulb included:	Yes - CREE	Lm:	160	USB_C:	Yes
Class:	Class II	Effi LS:	G	Shade:	No
IP:	20	CRI:	90,00	Dimmable:	No
Driver inc.:	Yes	Lamp Power:	3,00W		
Voltage/Frequence:	230V - 50Hz	Applied Standard:	CE / LVD		

PACKAGING DETAILS

	Individual Box	Outer Box	Master Box
Type:	MDC - BROWN PRINTED	MDC - MARRON / BROWN	
Units:	1.00	16.00	0.00
Measures:	0205-0100-0080	0345-0215-0430	
Gross Weight (kg):	0.57	9.32	-
CTN 40':	28.091,00		

OBSERVATIONS

USB-C socket 5VDC 2A

