

**TECHNICAL DATA 577536802**

LAMP INFO	
Description:	CL EROS XL Opal LED 100W Ø780mm CCT + RC
Mark:	10001 CL Ceiling
Reference:	577536802
Range:	57567 EROS
Code EAN:	8421797775360
Measures (mm):	0086-0785-0785
Weight (kg):	3.38

Lampholder/Watts:	LED 100W	CCT:	Progressive CCT 3000K-6500K	Switch:	Remote Control
Bulb included:	Yes - SMD	Lm:	9000	USB_C:	No
Class:	Class I	Effi LS:	F	Shade:	No
IP:	20	CRI:	87,10	Dimmable:	3 steps dimmer included
Driver inc.:	Yes	Lamp Power:	100,00W		
Voltage/Frequence:	230V - 50Hz	Applied Standard:	CE / LVD		

**PACKAGING DETAILS**

	Individual Box	Outer Box	Master Box
Type:	MDC-MARRON / BROWN		
Units:	1.00	0.00	0.00
Measures:	0845-0815-0100	_____	_____
Gross Weight (kg):	4.56	-	-
CTN 40':	813,00		

**OBSERVATIONS**

---



---



---



---



---

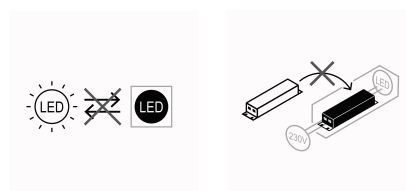

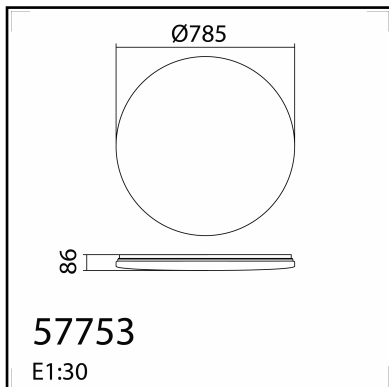

**TECHNICAL DATA 577536902**

**LAMP INFO**

<b>Description:</b>	CL EROS XL Starry LED 100W Ø780mm CCT + RC		
<b>Mark:</b>	10001	CL Ceiling	
<b>Reference:</b>	577536902		
<b>Range:</b>	57567	EROS	
<b>Code EAN:</b>	842179775377		
<b>Measures (mm):</b>	0086-0785-0785		
<b>Weight (kg):</b>	3.38		

<b>Lampholder/Watts:</b>	LED 100W	<b>CCT:</b>	Progressive CCT 3000K-6500K	<b>Switch:</b>	Remote Control
<b>Bulb included:</b>	Yes - SMD	<b>Lm:</b>	9000	<b>USB_C:</b>	No
<b>Class:</b>	Class I	<b>Effi LS:</b>	F	<b>Shade:</b>	No
<b>IP:</b>	20	<b>CRI:</b>	87,10	<b>Dimmable:</b>	3 steps dimmer included
<b>Driver inc.:</b>	Yes	<b>Lamp Power:</b>	100,00W		
<b>Voltage/Frequence:</b>	230V - 50Hz	<b>Applied Standard:</b>	CE / LVD		

**PACKAGING DETAILS**

	Individual Box	Outer Box	Master Box
<b>Type:</b>	MDC-MARRON / BROWN		
<b>Units:</b>	1.00	0.00	0.00
<b>Measures:</b>	0845-0815-0100	_____	_____
<b>Gross Weight (kg):</b>	4.56	-	-
<b>CTN 40':</b>	813,00		

**OBSERVATIONS**

---



---



---



---



---

