

TECHNICAL DATA 577068102

LAMP INFO	
Description:	WL PALACE blanco mate LED 3W + touch + USB 10W
Mark:	10002 WL Wall Lamp
Reference:	577068102
Range:	57705 PALACE
Code EAN:	8421797770686
Measures (mm):	0180-0080-0107
Weight (kg):	0.65

Lampholder/Watts:	LED 3W	CCT:	3000K	Switch:	Touch
Bulb included:	Yes - CREE	Lm:	145	USB_C:	No
Class:	Class II	Effi LS:	G	Shade:	No
IP:	20	CRI:	80,00	Dimmable:	No
Driver inc.:	Yes	Lamp Power:	3,50W		
Voltage/Frequence:	230V - 50Hz	Applied Standard:	CE / LVD		

PACKAGING DETAILS

	Individual Box	Outer Box	Master Box
Type:	MDC - BROWN PRINTED	MDC - MARRON / BROWN	
Units:	1.00	12.00	0.00
Measures:	0215-0110-0100	0450-0240-0325	
Gross Weight (kg):	0.78	9.47	
CTN 40':	19.145,00		

OBSERVATIONS

USB-A socket, 5VDC 2A

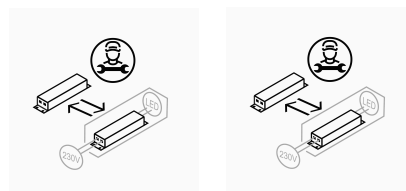

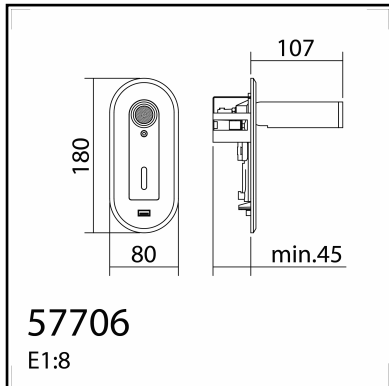

TECHNICAL DATA 577069102

LAMP INFO	
Description:	WL PALACE negro mate LED 3W + touch + USB 10W
Mark:	10002 WL Wall Lamp
Reference:	577069102
Range:	57705 PALACE
Code EAN:	8421797770693
Measures (mm):	0180-0080-0107
Weight (kg):	0.65

Lampholder/Watts:	LED 3W	CCT:	3000K	Switch:	Touch
Bulb included:	Yes - CREE	Lm:	145	USB_C:	Yes
Class:	Class II	Effi LS:	G	Shade:	No
IP:	20	CRI:	80,00	Dimmable:	No
Driver inc.:	Yes	Lamp Power:	3,50W		
Voltage/Frequence:	230V - 50Hz	Applied Standard:	CE / LVD		

PACKAGING DETAILS

	Individual Box	Outer Box	Master Box
Type:	MDC - BROWN PRINTED	MDC - MARRON / BROWN	
Units:	1.00	12.00	0.00
Measures:	0215-0110-0100	0450-0240-0325	
Gross Weight (kg):	0.78	9.47	
CTN 40':	19.145,00		

OBSERVATIONS

USB-A socket, 5VDC 2A

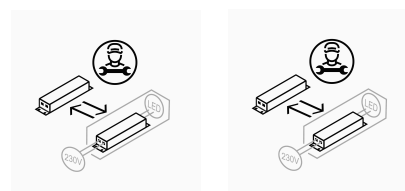

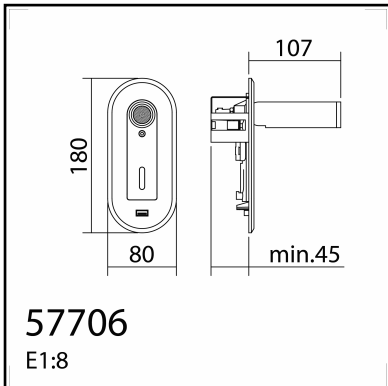

TECHNICAL DATA 577066109

LAMP INFO	
Description:	WL PALACE latón mate LED 3W + touch + USB C
Mark:	10002 WL Wall Lamp
Reference:	577066109
Range:	57705 PALACE
Code EAN:	8421797770679
Measures (mm):	0180-0080-0107
Weight (kg):	0.65

Lampholder/Watts:	LED 3W	CCT:	3000K	Switch:	Touch
Bulb included:	Yes - CREE	Lm:	145	USB_C:	Yes
Class:	Class II	Effi LS:	G	Shade:	No
IP:	20	CRI:	80,00	Dimmable:	No
Driver inc.:	Yes	Lamp Power:	3,50W		
Voltage/Frequence:	230V - 50Hz	Applied Standard:	CE / LVD		

PACKAGING DETAILS

	Individual Box	Outer Box	Master Box
Type:	MDC - BROWN PRINTED	MDC - MARRON / BROWN	
Units:	1.00	12.00	0.00
Measures:	0215-0110-0100	0450-0240-0325	
Gross Weight (kg):	0.78	9.47	
CTN 40':	19.145,00		

OBSERVATIONS

USB-C socket, 5VDC 2A

