

TECHNICAL DATA 577056102

LAMP INFO	
Description:	WL PALACE latón mate LED 3W + touch
Mark:	10002 WL Wall Lamp
Reference:	577056102
Range:	57705 PALACE
Code EAN:	8421797770563
Measures (mm):	0180-0080-0107
Weight (kg):	0.61

Lampholder/Watts:	LED 3W	CCT:	3000K	Switch:	Touch
Bulb included:	Yes - CREE	Lm:	160	USB_C:	No
Class:	Class II	Effi LS:	G	Shade:	No
IP:	20	CRI:	90,00	Dimmable:	No
Driver inc.:	Yes	Lamp Power:	3,00W		
Voltage/Frequence:	230V - 50Hz	Applied Standard:	CE / LVD		

PACKAGING DETAILS

	Individual Box	Outer Box	Master Box
Type:	MDC - BROWN PRINTED	MDC - MARRON / BROWN	
Units:	1.00	12.00	0.00
Measures:	0215-0110-0100	0450-0240-0325	
Gross Weight (kg):	0.73	8.80	-
CTN 40':	19.145,00		

OBSERVATIONS

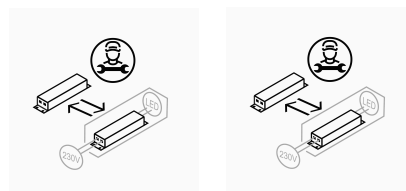

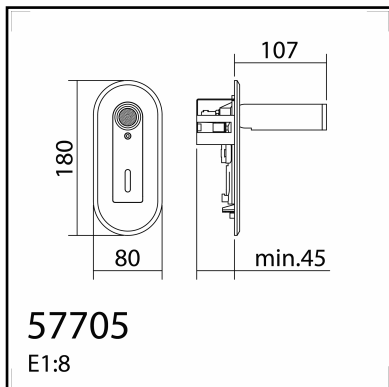

TECHNICAL DATA 577058102

LAMP INFO	
Description:	WL PALACE blanco mate LED 3W + touch
Mark:	10002 WL Wall Lamp
Reference:	577058102
Range:	57705 PALACE
Code EAN:	8421797770587
Measures (mm):	0180-0080-0107
Weight (kg):	0.61

Lampholder/Watts:	LED 3W	CCT:	3000K	Switch:	Touch
Bulb included:	Yes - CREE	Lm:	160	USB_C:	No
Class:	Class II	Effi LS:	G	Shade:	No
IP:	20	CRI:	90,00	Dimmable:	No
Driver inc.:	Yes	Lamp Power:	3,00W		
Voltage/Frequence:	230V - 50Hz	Applied Standard:	CE / LVD		

PACKAGING DETAILS

	Individual Box	Outer Box	Master Box
Type:	MDC - BROWN PRINTED	MDC - MARRON / BROWN	
Units:	1.00	12.00	0.00
Measures:	0215-0110-0100	0450-0240-0325	
Gross Weight (kg):	0.73	8.80	-
CTN 40':	19.145,00		

OBSERVATIONS

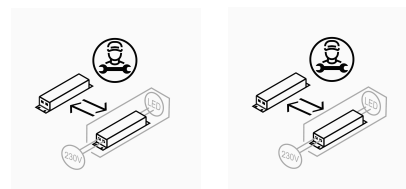

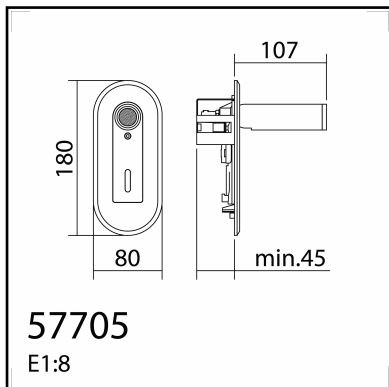

TECHNICAL DATA 577059102

LAMP INFO	
Description:	WL PALACE negro mate LED 3W + touch
Mark:	10002 WL Wall Lamp
Reference:	577059102
Range:	57705 PALACE
Code EAN:	8421797770594
Measures (mm):	0180-0080-0107
Weight (kg):	0.61

Lampholder/Watts:	LED 3W	CCT:	3000K	Switch:	Touch
Bulb included:	Yes - CREE	Lm:	160	USB_C:	No
Class:	Class II	Effi LS:	G	Shade:	No
IP:	20	CRI:	90,00	Dimmable:	No
Driver inc.:	Yes	Lamp Power:	3,00W		
Voltage/Frequence:	230V - 50Hz	Applied Standard:	CE / LVD		

PACKAGING DETAILS

	Individual Box	Outer Box	Master Box
Type:	MDC - BROWN PRINTED	MDC - MARRON / BROWN	
Units:	1.00	12.00	0.00
Measures:	0215-0110-0100	0450-0240-0325	
Gross Weight (kg):	0.73	8.80	-
CTN 40':	19.145,00		

OBSERVATIONS

