

57661
E1:20

TECHNICAL DATA 576618021

LAMP INFO

Description:	SUSPENSION CIRCUS, ø250mm 1"E27 (blanco)		
Mark:	10000	PD Pendant	
Reference:	576618021		
Range:	57661	CIRCUS	
Code EAN:	8421797766184		
Measures (mm):	1545-0250-0250		
Weight (kg):	0.64		

Lampholder/Watts:	E27 LED max.20W	CCT:	-	Switch:	No
Bulb included:	No	Lm:	-	USB_C:	No
Class:	Class II	Effi LS:	-	Shade:	No
IP:	20	CRI:	-	Dimmable:	No
Driver inc.:	No	Lamp Power:	-		
Voltage/Frequence:	230V - 50Hz	Applied Standard:	CE / LVD		

PACKAGING DETAILS

	Individual Box	Outer Box	Master Box
Type:	MDC - WHITE + COLOR LABEL		
Units:	1.00	0.00	0.00
Measures:	0290-0290-0270	_____	_____
Gross Weight (kg):	1.11	-	-
CTN 40':	2.466,00		

OBSERVATIONS

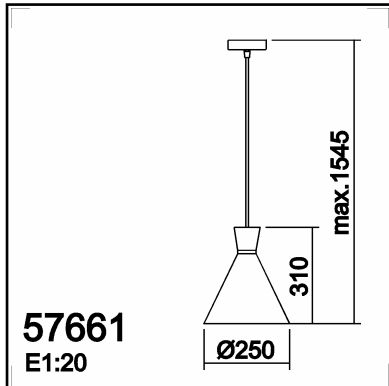

57661
E1:20

TECHNICAL DATA 576619021

LAMP INFO

Description:	SUSPENSION CIRCUS, ø250mm 1*E27 (negro)		
Mark:	10000	PD Pendant	
Reference:	576619021		
Range:	57661	CIRCUS	
Code EAN:	8421797766191		
Measures (mm):	1545-0250-0250		
Weight (kg):	0.64		

Lampholder/Watts:	E27 LED max.20W	CCT:	-	Switch:	No
Bulb included:	No	Lm:	-	USB_C:	No
Class:	Class II	Effi LS:	-	Shade:	No
IP:	20	CRI:	-	Dimmable:	No
Driver inc.:	No	Lamp Power:	-		
Voltage/Frequence:	230V - 50Hz	Applied Standard:	CE / LVD		

PACKAGING DETAILS

	Individual Box	Outer Box	Master Box
Type:	MDC - WHITE + COLOR LABEL		
Units:	1.00	0.00	0.00
Measures:	0290-0290-0270	_____	_____
Gross Weight (kg):	1.11	-	-
CTN 40':	2.466,00		

OBSERVATIONS
