

TECHNICAL DATA 576514387

LAMP INFO

Description:	LAMP MESA MOON,G9, touch (bronze)
Mark:	20001 TL Table Lamp
Reference:	576514387
Range:	57651 MOON
Code EAN:	8421797765149
Measures (mm):	0100-0100-0165
Weight (kg):	0.44

Lampholder/Watts:	G9 LED max. 8W	CCT:	-	Switch:	Touch
Bulb included:	No	Lm:	-	USB_C:	No
Class:	Class II	Effi LS:	-	Shade:	No
IP:	20	CRI:	-	Dimmable:	No
Driver inc.:	No	Lamp Power:	-		
Voltage/Frequence:	230V - 50Hz	Applied Standard:	CE / LVD		

PACKAGING DETAILS

	Individual Box	Outer Box	Master Box
Type:	MDC - WHITE + COLOR LABEL	MDC - MARRON / BROWN (c)	
Units:	1.00	12.00	0.00
Measures:	0180-0140-0200	0440-0380-0420	_____
Gross Weight (kg):	0.56	8.86	-
CTN 40':	9.569,00		

OBSERVATIONS

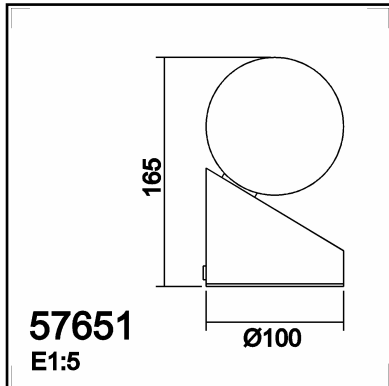

TECHNICAL DATA 576519787

LAMP INFO

Description:	LAMP MESA MOON,G9, touch (niquel mate)
Mark:	20001 TL Table Lamp
Reference:	576519787
Range:	57651 MOON
Code EAN:	8421797765194
Measures (mm):	0100-0100-0165
Weight (kg):	0.44

Lampholder/Watts:	G9 LED max. 8W	CCT:	-	Switch:	Touch
Bulb included:	No	Lm:	-	USB_C:	No
Class:	Class II	Effi LS:	-	Shade:	No
IP:	20	CRI:	-	Dimmable:	No
Driver inc.:	No	Lamp Power:	-		
Voltage/Frequence:	230V - 50Hz	Applied Standard:	CE / LVD		

PACKAGING DETAILS

	Individual Box	Outer Box	Master Box
Type:	MDC - WHITE + COLOR LABEL	MDC - MARRON / BROWN (c)	
Units:	1.00	12.00	0.00
Measures:	0180-0140-0200	0440-0380-0420	_____
Gross Weight (kg):	0.56	8.86	-
CTN 40':	9.569,00		

OBSERVATIONS
