

TECHNICAL DATA N° 2.940 - 576373525

LAMP INFO

Description:	APLIQUE ELEA 2*E27 (cr mate+pant blanca)		
Mark:	10002 WL Wall Lamp		
Reference:	576373525		
Provisional Ref.:			
Range:	57635 ELEA		
Code EAN:	8421797763732		
Measures (mm):	0255-0320-0117	Weight (kg):	0.60

TECHNICAL INFO

Lampholder/Watts:	2xE27 max.40W	Switch:	No	Transformer:	No
Bulb included:	No	Dimmer:	No	Voltage/Frequence:	230V - 50Hz
CCT:	-	Efi:	A++..E	Shade:	Yes
Lm:	-	Ra:	-	Shrink wrap:	No
Class:	II	Bulk:	No	Applied Standard:	CE / LVD
IP:	20	McAdam:	-	Power:	-

PACKAGING DETAILS

	Individual Box	Outer Box	Master Box
Type:	MDC-MARRON / BROWN	MDC - MARRON / BROWN	
Units:	1.00	6.00	0.00
Measures:	0280-0115-0340	0580-0400-0365	_____
Gross Weight (kg):	0.75	5.30	-
CTN 40':	3.967,00		

OBSERVATIONS

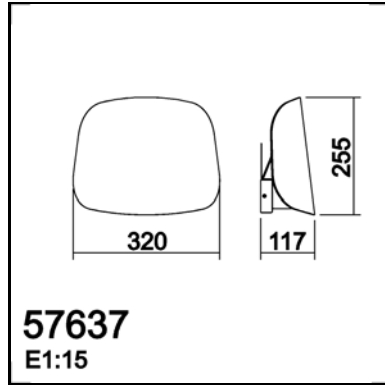

TECHNICAL DATA N° 2.941 - 576378125

LAMP INFO

Description:	APLIQUE ELEA 2*E27 (bl mate+pant blanca)		
Mark:	10002 WL Wall Lamp		
Reference:	576378125		
Provisional Ref.:			
Range:	57635 ELEA		
Code EAN:	8421797763787		
Measures (mm):	0255-0320-0117	Weight (kg):	0.60

TECHNICAL INFO

Lampholder/Watts:	2xE27 max.40W	Switch:	No	Transformer:	No
Bulb included:	No	Dimmer:	No	Voltage/Frequence:	230V - 50Hz
CCT:	-	Efi:	A++..E	Shade:	Yes
Lm:	-	Ra:	-	Shrink wrap:	No
Class:	II	Bulk:	No	Applied Standard:	CE / LVD
IP:	20	McAdam:	-	Power:	-

PACKAGING DETAILS

	Individual Box	Outer Box	Master Box
Type:	MDC-MARRON / BROWN	MDC - MARRON / BROWN	
Units:	1.00	6.00	0.00
Measures:	0280-0115-0340	0580-0400-0365	_____
Gross Weight (kg):	0.75	5.30	-
CTN 40':	3.967,00		

OBSERVATIONS
