

TECHNICAL DATA 576305902

LAMP INFO

Description:	APLIQUE NORA, 2*7W 3000K (negro mate+lato mate)		
Mark:	10002	WL Wall Lamp	
Reference:	576305902		
Range:	57630	NORA	
Code EAN:	8421797763053		
Measures (mm):	0300-0125-0062		
Weight (kg):	0.85		

Lampholder/Watts:	LED 2x7W	CCT:	3000K	Switch:	No
Bulb included:	Yes - SMD	Lm:	750	USB_C:	No
Class:	Class II	Effi LS:	F	Shade:	No
IP:	20	CRI:	92,00	Dimmable:	No
Driver inc.:	Yes	Lamp Power:	14,00W		
Voltage/Frequence:	230V - 50Hz	Applied Standard:	CE / LVD		

PACKAGING DETAILS

	Individual Box	Outer Box	Master Box
Type:	MDC - BROWN PRINTED	MDC - MARRON / BROWN	
Units:	1.00	12.00	0.00
Measures:	0160-0090-0340	0505-0390-0360	
Gross Weight (kg):	1.02	12.90	
CTN 40':	9.477,00		

OBSERVATIONS

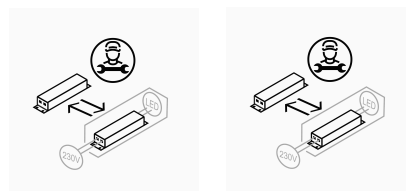

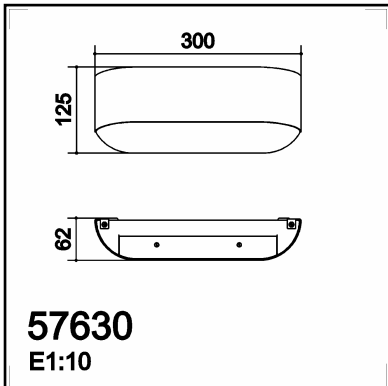

TECHNICAL DATA 576308102

LAMP INFO

Description:	APLIQUE NORA, 2*7W 3000K (blanco mate)		
Mark:	10002	WL Wall Lamp	
Reference:	576308102		
Range:	57630	NORA	
Code EAN:	8421797763084		
Measures (mm):	0300-0125-0062		
Weight (kg):	0.85		

Lampholder/Watts:	LED 2x7W	CCT:	3000K	Switch:	No
Bulb included:	Yes - SMD	Lm:	750	USB_C:	No
Class:	Class II	Effi LS:	F	Shade:	No
IP:	20	CRI:	92,00	Dimmable:	No
Driver inc.:	Yes	Lamp Power:	14,00W		
Voltage/Frequence:	230V - 50Hz	Applied Standard:	CE / LVD		

PACKAGING DETAILS

	Individual Box	Outer Box	Master Box
Type:	MDC - BROWN PRINTED	MDC - MARRON / BROWN	
Units:	1.00	12.00	0.00
Measures:	0160-0090-0340	0505-0390-0360	
Gross Weight (kg):	1.02	12.90	
CTN 40°:	9.477,00		

OBSERVATIONS

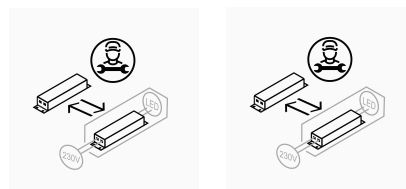

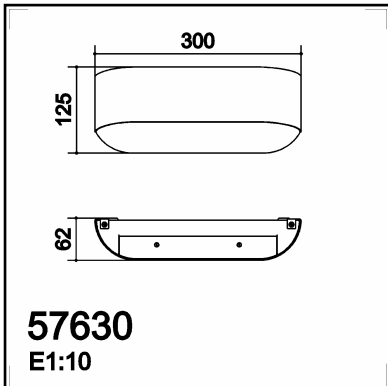

TECHNICAL DATA 576309702

LAMP INFO	
Description:	APLIQUE NORA, 2*7W 3000K (niquel mate)
Mark:	10002 WL Wall Lamp
Reference:	576309702
Range:	57630 NORA
Code EAN:	8421797763091
Measures (mm):	0300-0125-0062
Weight (kg):	0.85

Lampholder/Watts:	LED 2x7W	CCT:	3000K	Switch:	No
Bulb included:	Yes - SMD	Lm:	750	USB_C:	No
Class:	Class II	Effi LS:	F	Shade:	No
IP:	20	CRI:	92,00	Dimmable:	No
Driver inc.:	Yes	Lamp Power:	14,00W		
Voltage/Frequence:	230V - 50Hz	Applied Standard:	CE / LVD		

PACKAGING DETAILS

	Individual Box	Outer Box	Master Box
Type:	MDC - BROWN PRINTED	MDC - MARRON / BROWN	
Units:	1.00	12.00	0.00
Measures:	0160-0090-0340	0505-0390-0360	
Gross Weight (kg):	1.02	12.90	
CTN 40':	9.477,00		

OBSERVATIONS

