

TECHNICAL DATA 575188020

LAMP INFO	
Description:	LAMP PIE CALA ,LED 5W 380lum (blanco)
Mark:	20000 FL Floor Lamp
Reference:	575188020
Range:	57550 CALA
Code EAN:	8421797751883
Measures (mm):	1500-0230-0230
Weight (kg):	1.50

Lampholder/Watts:	LED 5W	CCT:	4000K	Switch:	Foot switch
Bulb included:	Yes - SMD	Lm:	380	USB_C:	No
Class:	Class II	Effi LS:	D	Shade:	No
IP:	20	CRI:	80,00	Dimmable:	No
Driver inc.:	Yes	Lamp Power:	5,00W		
Voltage/Frequence:	230V - 50Hz	Applied Standard:	CE / LVD		

PACKAGING DETAILS

	Individual Box	Outer Box	Master Box
Type:	MDC - COLORS	MDC - MARRON / BROWN (c)	
Units:	1.00	4.00	0.00
Measures:	0370-0240-0090	0375-0255-0390	_____
Gross Weight (kg):	1.88	11.50	-
CTN 40':	6.006,00		

OBSERVATIONS

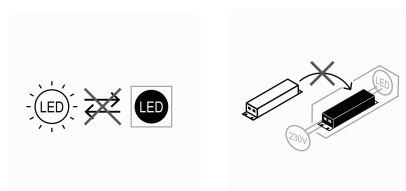

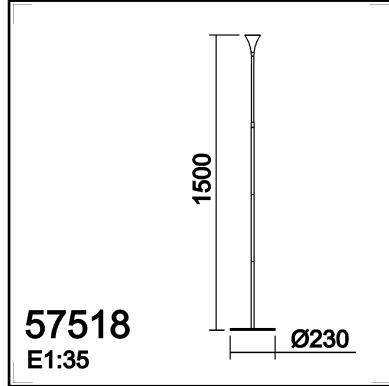

TECHNICAL DATA 575183020

LAMP INFO	
Description:	LAMP PIE CALA ,LED 5W 380lum (gris)
Mark:	20000 FL Floor Lamp
Reference:	575183020
Range:	57550 CALA
Code EAN:	8421797751838
Measures (mm):	1500-0230-0230
Weight (kg):	1.50

Lampholder/Watts:	LED 5W	CCT:	4000K	Switch:	Foot switch
Bulb included:	Yes - SMD	Lm:	380	USB_C:	No
Class:	Class II	Effi LS:	D	Shade:	No
IP:	20	CRI:	80,00	Dimmable:	No
Driver inc.:	Yes	Lamp Power:	5,00W		
Voltage/Frequence:	230V - 50Hz	Applied Standard:	CE / LVD		

PACKAGING DETAILS

	Individual Box	Outer Box	Master Box
Type:	MDC - COLORS	MDC - MARRON / BROWN (c)	
Units:	1.00	4.00	0.00
Measures:	0370-0240-0090	0375-0255-0390	_____
Gross Weight (kg):	1.88	11.50	-
CTN 40':	6.006,00		

OBSERVATIONS

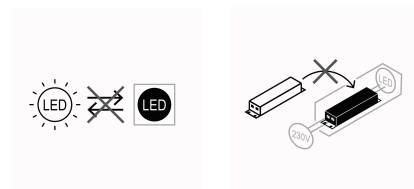

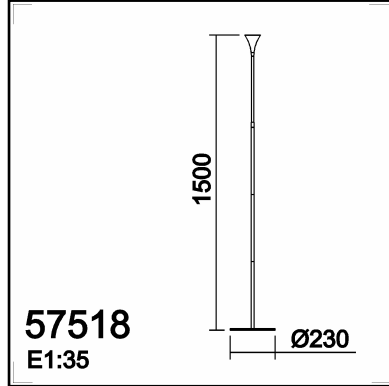

TECHNICAL DATA 575189020

LAMP INFO	
Description:	LAMP PIE CALA ,LED 5W 380lum (negro)
Mark:	20000 FL Floor Lamp
Reference:	575189020
Range:	57550 CALA
Code EAN:	8421797751890
Measures (mm):	1500-0230-0230
Weight (kg):	1.50

Lampholder/Watts:	LED 5W	CCT:	4000K	Switch:	Foot switch
Bulb included:	Yes - SMD	Lm:	380	USB_C:	No
Class:	Class II	Effi LS:	D	Shade:	No
IP:	20	CRI:	80,00	Dimmable:	No
Driver inc.:	Yes	Lamp Power:	5,00W		
Voltage/Frequence:	230V - 50Hz	Applied Standard:	CE / LVD		

PACKAGING DETAILS

	Individual Box	Outer Box	Master Box
Type:	MDC - COLORS	MDC - MARRON / BROWN (c)	
Units:	1.00	4.00	0.00
Measures:	0370-0240-0090	0375-0255-0390	
Gross Weight (kg):	1.88	11.50	-
CTN 40':	6.006,00		

OBSERVATIONS

