

**TECHNICAL DATA 570634321**

LAMP INFO	
Description:	SUSPENSION NEXY, E27 (bronce)
Mark:	10000 PD Pendant
Reference:	570634321
Range:	57063 NEXI
Code EAN:	8421797706340
Measures (mm):	0330-1500-0330
Weight (kg):	2.00

Lampholder/Watts:	E27 LED max.20W	CCT:	-	Switch:	No
Bulb included:	No	Lm:	-	USB_C:	No
Class:	Class II	Effi LS:	-	Shade:	No
IP:	20	CRI:	-	Dimmable:	No
Driver inc.:	No	Lamp Power:	-		
Voltage/Frequence:	230V - 50Hz	Applied Standard:	CE / LVD		

PACKAGING DETAILS			
	Individual Box	Outer Box	Master Box
Type:	MDC - BROWN PRINTED	MDC - MARRON / BROWN	
Units:	1.00	2.00	0.00
Measures:	0355-0355-0235	0370-0370-0485	
Gross Weight (kg):	2.20	4.98	-
CTN 40':	1.686,00		

OBSERVATIONS

---



---



---



---



---

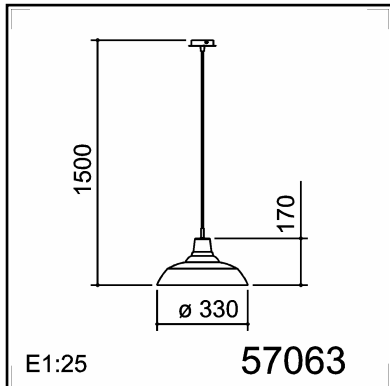

**TECHNICAL DATA 570637821**

LAMP INFO	
Description:	SUSPENSION NEXY, E27 (oxido rojo)
Mark:	10000 PD Pendant
Reference:	570637821
Range:	57063 NEXI
Code EAN:	8421797706371
Measures (mm):	0330-1500-0330
Weight (kg):	2.00

Lampholder/Watts:	E27 LED max.20W	CCT:	-	Switch:	No
Bulb included:	No	Lm:	-	USB_C:	No
Class:	Class II	Effi LS:	-	Shade:	No
IP:	20	CRI:	-	Dimmable:	No
Driver inc.:	No	Lamp Power:	-		
Voltage/Frequence:	230V - 50Hz	Applied Standard:	CE / LVD		

PACKAGING DETAILS			
	Individual Box	Outer Box	Master Box
Type:	MDC - BROWN PRINTED	MDC - MARRON / BROWN	
Units:	1.00	2.00	0.00
Measures:	0355-0355-0235	0370-0370-0485	
Gross Weight (kg):	2.20	4.98	-
CTN 40':	1.686,00		

**OBSERVATIONS**

---



---



---



---



---

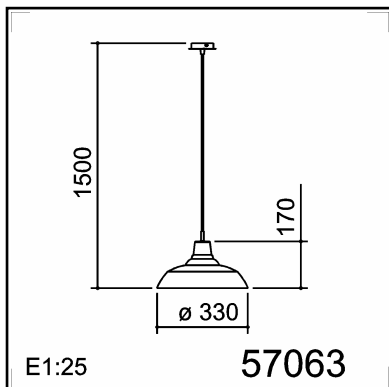

**TECHNICAL DATA 570639221**

LAMP INFO	
Description:	SUSPENSION NEXY, E27 (negro piedra)
Mark:	10000 PD Pendant
Reference:	570639221
Range:	57063 NEXI
Code EAN:	8421797706388
Measures (mm):	0330-1500-0330
Weight (kg):	2.00

Lampholder/Watts:	E27 LED max.20W	CCT:	-	Switch:	No
Bulb included:	No	Lm:	-	USB_C:	No
Class:	Class II	Effi LS:	-	Shade:	No
IP:	20	CRI:	-	Dimmable:	No
Driver inc.:	No	Lamp Power:	-		
Voltage/Frequence:	230V - 50Hz	Applied Standard:	CE / LVD		

PACKAGING DETAILS			
	Individual Box	Outer Box	Master Box
Type:	MDC - BROWN PRINTED	MDC - MARRON / BROWN	
Units:	1.00	2.00	0.00
Measures:	0355-0355-0235	0370-0370-0485	
Gross Weight (kg):	2.20	4.98	-
CTN 40':	1.686,00		

OBSERVATIONS

---



---



---



---



---

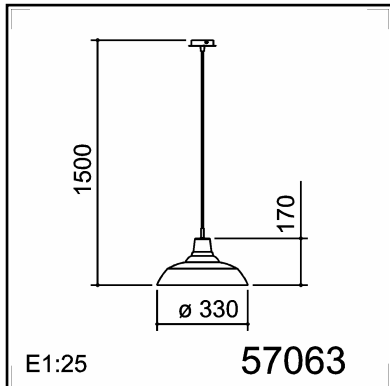

**TECHNICAL DATA 570639721**

LAMP INFO	
Description:	SUSPENSION NEXY, E27 (niquel mate)
Mark:	10000 PD Pendant
Reference:	570639721
Range:	57063 NEXI
Code EAN:	8421797706395
Measures (mm):	0330-1500-0330
Weight (kg):	2.00

Lampholder/Watts:	E27 LED max.20W	CCT:	-	Switch:	No
Bulb included:	No	Lm:	-	USB_C:	No
Class:	Class II	Effi LS:	-	Shade:	No
IP:	20	CRI:	-	Dimmable:	No
Driver inc.:	No	Lamp Power:	-		
Voltage/Frequence:	230V - 50Hz	Applied Standard:	CE / LVD		

PACKAGING DETAILS			
	Individual Box	Outer Box	Master Box
Type:	MDC - BROWN PRINTED	MDC - MARRON / BROWN	
Units:	1.00	2.00	0.00
Measures:	0355-0355-0235	0370-0370-0485	
Gross Weight (kg):	2.20	4.98	
CTN 40':	1.686,00		

OBSERVATIONS

---



---



---



---



---