

TECHNICAL DATA 570144401

LAMP INFO

Description:	FOCO OUVI, regl 4*GU10 (medalla)		
Mark:	10003	SL Spot Light	
Reference:	570144401		
Range:	57010	OUVI	
Code EAN:	8421797701444		
Measures (mm):	0550-0040-0114		
Weight (kg):	0.61		

Lampholder/Watts:	4xGU10 LED max.10W	CCT:	-	Switch:	No
Bulb included:	No	Lm:	-	USB_C:	No
Class:	Class I	Effi LS:	-	Shade:	No
IP:	20	CRI:	-	Dimmable:	No
Driver inc.:	No	Lamp Power:	-		
Voltage/Frequence:	230V - 50Hz	Applied Standard:	CE / LVD		

PACKAGING DETAILS

	Individual Box	Outer Box	Master Box
Type:	MDC - BROWN PRINTED	MDC - MARRON / BROWN (c)	
Units:	1.00	6.00	0.00
Measures:	0115-0565-0050	0250-0585-0170	_____
Gross Weight (kg):	0.76	4.90	-
CTN 40°:	13.514,00		

OBSERVATIONS

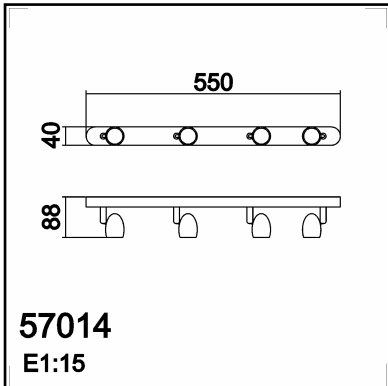

TECHNICAL DATA 570143501

LAMP INFO

Description:	FOCO OUVI, regl 4*GU10 (cromo mate)		
Mark:	10003	SL Spot Light	
Reference:	570143501		
Range:	57010	OUVI	
Code EAN:	8421797701420		
Measures (mm):	0550-0040-0114		
Weight (kg):	0.61		

Lampholder/Watts:	4xGU10 LED max.10W	CCT:	-	Switch:	No
Bulb included:	No	Lm:	-	USB_C:	No
Class:	Class I	Effi LS:	-	Shade:	No
IP:	20	CRI:	-	Dimmable:	No
Driver inc.:	No	Lamp Power:	-		
Voltage/Frequence:	230V - 50Hz	Applied Standard:	CE / LVD		

PACKAGING DETAILS

	Individual Box	Outer Box	Master Box
Type:	MDC - BROWN PRINTED	MDC - MARRON / BROWN (c)	
Units:	1.00	6.00	0.00
Measures:	0115-0565-0050	0250-0585-0170	_____
Gross Weight (kg):	0.76	4.90	-
CTN 40°:	13.514,00		

OBSERVATIONS

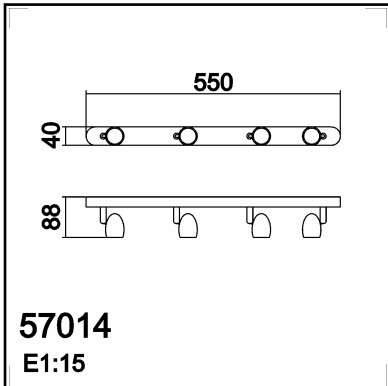

TECHNICAL DATA 570148001

LAMP INFO

Description:	FOCO OUVI, regl 4*GU10 (blanco)		
Mark:	10003	SL Spot Light	
Reference:	570148001		
Range:	57010	OUVI	
Code EAN:	8421797701482		
Measures (mm):	0550-0040-0114		
Weight (kg):	0.61		

Lampholder/Watts:	4xGU10 LED max.10W	CCT:	-	Switch:	No
Bulb included:	No	Lm:	-	USB_C:	No
Class:	Class I	Effi LS:	-	Shade:	No
IP:	20	CRI:	-	Dimmable:	No
Driver inc.:	No	Lamp Power:	-		
Voltage/Frequence:	230V - 50Hz	Applied Standard:	CE / LVD		

PACKAGING DETAILS

	Individual Box	Outer Box	Master Box
Type:	MDC - BROWN PRINTED	MDC - MARRON / BROWN (c)	
Units:	1.00	6.00	0.00
Measures:	0115-0565-0050	0250-0585-0170	_____
Gross Weight (kg):	0.76	4.90	-
CTN 40°:	13.514,00		

OBSERVATIONS
