

TECHNICAL DATA N° 1.971 - 568894461

LAMP INFO

Description:	APLIQUE LION, E14 48W (medalla)		
Mark:	10002 WL Wall Lamp		
Reference:	568894461		
Provisional Ref.:			
Range:	56889 LION		
Code EAN:	8421797688967		
Measures (mm):	0170-0260-0373	Weight (kg):	0.75

TECHNICAL INFO

Lampholder/Watts:	E14 max.48W	Switch:	Toggle switch	Transformer:	No
Bulb included:	No	Dimmer:	Yes	Voltage/Frequence:	230V - 50Hz
CCT:	-	Efi:	A++..E	Shade:	Yes
Lm:	-	Ra:	-	Shrink wrap:	No
Class:	I	Bulk:	No	Applied Standard:	CE / LVD
IP:	20	McAdam:	-	Power:	-

PACKAGING DETAILS

	Individual Box	Outer Box	Master Box
Type:	MDC-MARRON IMPRESA	MDC - MARRON / BROWN	
Units:	1.00	4.00	0.00
Measures:	0220-0185-0220	0460-0390-0240	_____
Gross Weight (kg):	0.90	3.31	-
CTN 40':	5.202,00		

OBSERVATIONS

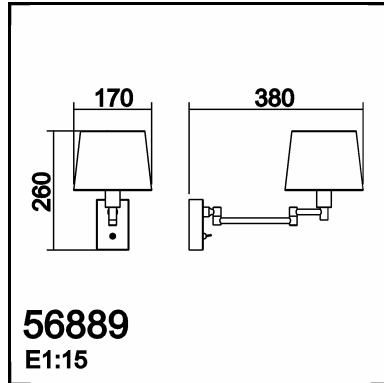
TECHNICAL DATA N° 1.970 - 568893561
LAMP INFO

Description:	APLIQUE LION, E14 48W (cromo mate)		
Mark:	10002 WL Wall Lamp		
Reference:	568893561		
Provisional Ref.:			
Range:	56889 LION		
Code EAN:	8421797688950		
Measures (mm):	0260-0170-0373	Weight (kg):	0.75

TECHNICAL INFO

Lampholder/Watts:	E14 max.48W	Switch:	Toggle switch	Transformer:	No
Bulb included:	No	Dimmer:	Yes	Voltage/Frequence:	230V - 50Hz
CCT:	-	Efi:	A++..E	Shade:	Yes
Lm:	-	Ra:	-	Shrink wrap:	No
Class:	I	Bulk:	No	Applied Standard:	CE / LVD
IP:	20	McAdam:	-	Power:	-

PACKAGING DETAILS

	Individual Box	Outer Box	Master Box
Type:	MDC-MARRON IMPRESA	MDC - MARRON / BROWN	
Units:	1.00	4.00	0.00
Measures:	0220-0185-0220	0460-0390-0240	_____
Gross Weight (kg):	0.90	3.31	-
CTN 40':	5.202,00		

OBSERVATIONS
