

TECHNICAL DATA 567533031

LAMP INFO

Description:	LAMP PIE KIT, E27(cr. brillo)+retr.		
Mark:	20000	FL Floor Lamp	
Reference:	567533031		
Range:	56752	KIT	
Code EAN:	8421797675332		
Measures (mm):	0250-0250-1325		
Weight (kg):	1.53		

Lampholder/Watts:	E27 LED max.20W	CCT:	-	Switch:	Foot switch
Bulb included:	No	Lm:	-	USB_C:	No
Class:	Class II	Effi LS:	-	Shade:	No
IP:	20	CRI:	-	Dimmable:	No
Driver inc.:	No	Lamp Power:	-		
Voltage/Frequence:	230V - 50Hz	Applied Standard:	CE / LVD		

PACKAGING DETAILS

	Individual Box	Outer Box	Master Box
Type:	MDC - COLORS	MDC - MARRON / BROWN (c)	
Units:	1.00	5.00	0.00
Measures:	0275-0070-0500	0380-0290-0520	_____
Gross Weight (kg):	1.83	9.70	-
CTN 40':	4.886,00		

OBSERVATIONS

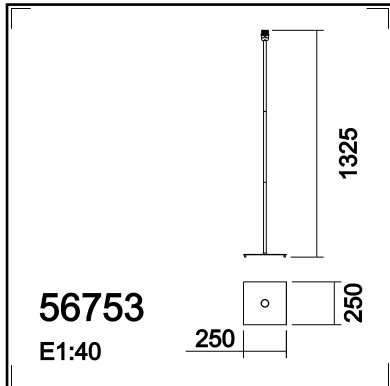

TECHNICAL DATA 567539031

LAMP INFO

Description:	LAMP PIE KIT, E27(negro)+retr.
Mark:	20000 FL Floor Lamp
Reference:	567539031
Range:	56752 KIT
Code EAN:	8421797675394
Measures (mm):	0250-0250-1325
Weight (kg):	1.53

Lampholder/Watts:	E27 LED max.20W	CCT:	-	Switch:	Foot switch
Bulb included:	No	Lm:	-	USB_C:	No
Class:	Class II	Effi LS:	-	Shade:	No
IP:	20	CRI:	-	Dimmable:	No
Driver inc.:	No	Lamp Power:	-		
Voltage/Frequence:	230V - 50Hz	Applied Standard:	CE / LVD		

PACKAGING DETAILS

	Individual Box	Outer Box	Master Box
Type:	MDC - COLORS	MDC - MARRON / BROWN (c)	
Units:	1.00	5.00	0.00
Measures:	0275-0070-0500	0380-0290-0520	_____
Gross Weight (kg):	1.83	9.70	-
CTN 40':	4.886,00		

OBSERVATIONS

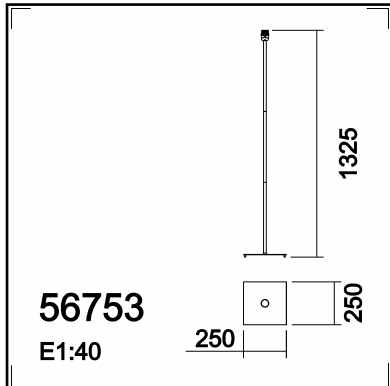

TECHNICAL DATA 567533531

LAMP INFO

Description:	LAMP PIE, E27(cr.mate)+retr.
Mark:	20000 FL Floor Lamp
Reference:	567533531
Range:	56752 KIT
Code EAN:	8421797675349
Measures (mm):	0250-0250-1325
Weight (kg):	1.53

Lampholder/Watts:	E27 LED max.20W	CCT:	-	Switch:	Foot switch
Bulb included:	No	Lm:	-	USB_C:	No
Class:	Class II	Effi LS:	-	Shade:	No
IP:	20	CRI:	-	Dimmable:	No
Driver inc.:	No	Lamp Power:	-		
Voltage/Frequence:	230V - 50Hz	Applied Standard:	CE / LVD		

PACKAGING DETAILS

	Individual Box	Outer Box	Master Box
Type:	MDC - COLORS	MDC - MARRON / BROWN (c)	
Units:	1.00	5.00	0.00
Measures:	0275-0070-0500	0380-0290-0520	_____
Gross Weight (kg):	1.83	9.70	-
CTN 40':	4.886,00		

OBSERVATIONS

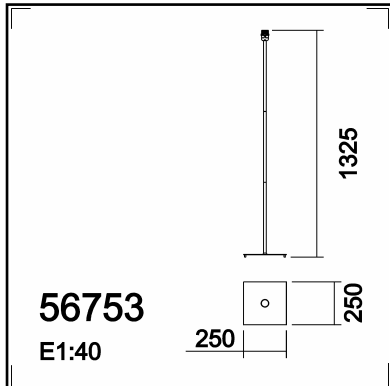

TECHNICAL DATA 567537531

LAMP INFO

Description:	LAMP PIE, E27(marrón oxido)+retr.
Mark:	20000 FL Floor Lamp
Reference:	567537531
Range:	56752 KIT
Code EAN:	8421797675370
Measures (mm):	0250-0250-1325
Weight (kg):	1.53

Lampholder/Watts:	E27 LED max.20W	CCT:	-	Switch:	Foot switch
Bulb included:	No	Lm:	-	USB_C:	No
Class:	Class II	Effi LS:	-	Shade:	No
IP:	20	CRI:	-	Dimmable:	No
Driver inc.:	No	Lamp Power:	-		
Voltage/Frequence:	230V - 50Hz	Applied Standard:	CE / LVD		

PACKAGING DETAILS

	Individual Box	Outer Box	Master Box
Type:	MDC - COLORS	MDC - MARRON / BROWN (c)	
Units:	1.00	5.00	0.00
Measures:	0275-0070-0500	0380-0290-0520	_____
Gross Weight (kg):	1.83	9.70	-
CTN 40':	4.886,00		

OBSERVATIONS

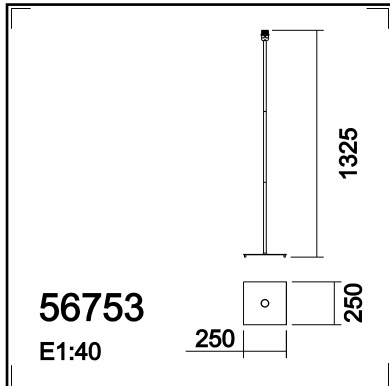

TECHNICAL DATA 567538131

LAMP INFO

Description:	LAMP PIE KIT, E27(blanco mate)+retr.		
Mark:	20000	FL Floor Lamp	
Reference:	567538131		
Range:	56752	KIT	
Code EAN:	8421797675387		
Measures (mm):	0250-0250-1325		
Weight (kg):	1.53		

Lampholder/Watts:	E27 LED max.20W	CCT:	-	Switch:	Foot switch
Bulb included:	No	Lm:	-	USB_C:	No
Class:	Class II	Effi LS:	-	Shade:	No
IP:	20	CRI:	-	Dimmable:	No
Driver inc.:	No	Lamp Power:	-		
Voltage/Frequence:	230V - 50Hz	Applied Standard:	CE / LVD		

PACKAGING DETAILS

	Individual Box	Outer Box	Master Box
Type:	MDC - COLORS	MDC - MARRON / BROWN (c)	
Units:	1.00	5.00	0.00
Measures:	0275-0070-0500	0380-0290-0520	_____
Gross Weight (kg):	1.83	9.70	-
CTN 40':	4.886,00		

OBSERVATIONS
