

**56388**

**E1:30**

**TECHNICAL DATA 563883025**

LAMP INFO	
Description:	L. PIE HAL. SLIVA, R7s+G9 (cromo brillo) +bomb
Mark:	20000 FL Floor Lamp
Reference:	563883025
Range:	56388 SLIVA
Code EAN:	8421797638825
Measures (mm):	0280-1845-0280
Weight (kg):	7.00

Lampholder/Watts:	R7s LED max. 40W + G9 LED max. 8W	CCT:	-	Switch:	Toggle + push switch
Bulb included:	No	Lm:	-	USB_C:	No
Class:	Class I	Effi LS:	-	Shade:	No
IP:	20	CRI:	-	Dimmable:	Progressive 0-100% dimmer included
Driver inc.:	No	Lamp Power:	-		
Voltage/Frequence:	230V - 50Hz	Applied Standard:	CE / LVD		

**PACKAGING DETAILS**

	Individual Box	Outer Box	Master Box
Type:	MDC - BROWN PRINTED		
Units:	1.00	0.00	0.00
Measures:	1070-0315-0315	_____	_____
Gross Weight (kg):	8.50	-	-
CTN 40':	527,00		

**OBSERVATIONS**

---



---



---



---



---

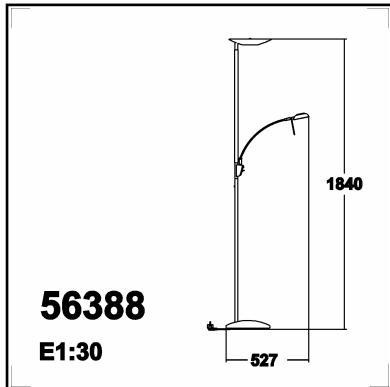

**56388**

**E1:30**

**TECHNICAL DATA 563883525**

**LAMP INFO**

<b>Description:</b>	L. PIE HAL. SLIVA, R7s+G9 (cromo cep.)
<b>Mark:</b>	20000 FL Floor Lamp
<b>Reference:</b>	563883525
<b>Range:</b>	56388 SLIVA
<b>Code EAN:</b>	8421797638832
<b>Measures (mm):</b>	0280-1845-0280
<b>Weight (kg):</b>	7.00

<b>Lampholder/Watts:</b>	R7s LED max. 40W + G9 LED max. 8W	<b>CCT:</b>	-	<b>Switch:</b>	Toggle + push switch
<b>Bulb included:</b>	No	<b>Lm:</b>	-	<b>USB_C:</b>	No
<b>Class:</b>	Class I	<b>Effi LS:</b>	-	<b>Shade:</b>	No
<b>IP:</b>	20	<b>CRI:</b>	-	<b>Dimmable:</b>	Progressive 0-100% dimmer included
<b>Driver inc.:</b>	No	<b>Lamp Power:</b>	-		
<b>Voltage/Frequence:</b>	230V - 50Hz	<b>Applied Standard:</b>	CE / LVD		

**PACKAGING DETAILS**

	Individual Box	Outer Box	Master Box
<b>Type:</b>	MDC - BROWN PRINTED		
<b>Units:</b>	1.00	0.00	0.00
<b>Measures:</b>	1070-0315-0315	_____	_____
<b>Gross Weight (kg):</b>	8.50	-	-
<b>CTN 40':</b>	527,00		

**OBSERVATIONS**

---



---



---



---



---

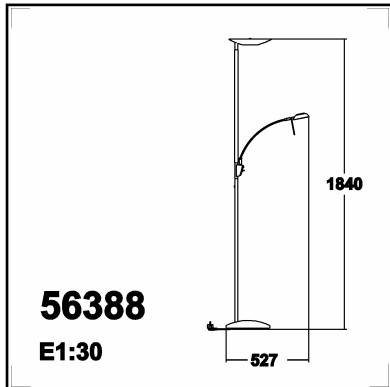

**TECHNICAL DATA 563884425**

**LAMP INFO**

<b>Description:</b>	L. PIE HAL. SLIVA, R7s+G9 (medalla) +bomb
<b>Mark:</b>	20000 FL Floor Lamp
<b>Reference:</b>	563884425
<b>Range:</b>	56388 SLIVA
<b>Code EAN:</b>	8421797638849
<b>Measures (mm):</b>	0280-1845-0280
<b>Weight (kg):</b>	7.00

<b>Lampholder/Watts:</b>	R7s LED max. 40W + G9 LED max. 8W	<b>CCT:</b>	-	<b>Switch:</b>	Toggle + push switch
<b>Bulb included:</b>	No	<b>Lm:</b>	-	<b>USB_C:</b>	No
<b>Class:</b>	Class I	<b>Effi LS:</b>	-	<b>Shade:</b>	No
<b>IP:</b>	20	<b>CRI:</b>	-	<b>Dimmable:</b>	Progressive 0-100% dimmer included
<b>Driver inc.:</b>	No	<b>Lamp Power:</b>	-		
<b>Voltage/Frequence:</b>	230V - 50Hz	<b>Applied Standard:</b>	CE / LVD		

**PACKAGING DETAILS**

	Individual Box	Outer Box	Master Box
<b>Type:</b>	MDC - BROWN PRINTED		
<b>Units:</b>	1.00	0.00	0.00
<b>Measures:</b>	1070-0315-0315	_____	_____
<b>Gross Weight (kg):</b>	8.50	-	-
<b>CTN 40':</b>	527,00		

**OBSERVATIONS**

---



---



---



---



---