

TECHNICAL DATA 450236101

LAMP INFO	
Description:	PL JULIETTE W laton mate+ nogal 3xE27
Mark:	10002 WL Wall Lamp
Reference:	450236101
Range:	58060 JULIETTE
Code EAN:	8421797502362
Measures (mm):	0157-0157-1500
Weight (kg):	0.50

Lampholder/Watts:	3xE27 LED max.20W	CCT:	-	Switch:	No
Bulb included:	No	Lm:	-	USB_C:	No
Class:	Class II	Effi LS:	-	Shade:	No
IP:	20	CRI:	-	Dimmable:	No
Driver inc.:	No	Lamp Power:	-		
Voltage/Frequence:	230V - 50Hz	Applied Standard:	CE / LVD		

PACKAGING DETAILS

	Individual Box	Outer Box	Master Box
Type:	MDC - BROWN PRINTED	MDC - MARRON / BROWN	
Units:	1.00	8.00	0.00
Measures:	0180-0180-0275	0380-0380-0575	
Gross Weight (kg):	0.70	7.40	-
CTN 40':	5.395,00		

OBSERVATIONS

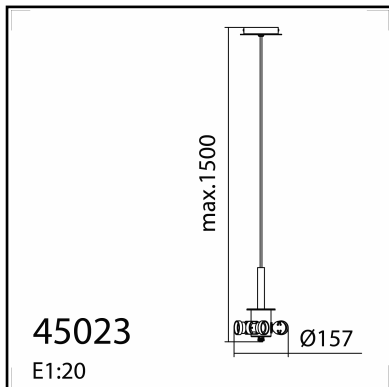

45023
E1:20

TECHNICAL DATA 450239101

LAMP INFO	
Description:	PL JULIETTE W negro + natural 3xE27
Mark:	10002 WL Wall Lamp
Reference:	450239101
Range:	58060 JULIETTE
Code EAN:	8421797502393
Measures (mm):	0157-0157-1500
Weight (kg):	0.50

Lampholder/Watts:	3xE27 LED max.20W	CCT:	-	Switch:	No
Bulb included:	No	Lm:	-	USB_C:	No
Class:	Class II	Effi LS:	-	Shade:	No
IP:	20	CRI:	-	Dimmable:	No
Driver inc.:	No	Lamp Power:	-		
Voltage/Frequence:	230V - 50Hz	Applied Standard:	CE / LVD		

PACKAGING DETAILS			
	Individual Box	Outer Box	Master Box
Type:	MDC - BROWN PRINTED	MDC - MARRON / BROWN	
Units:	1.00	8.00	0.00
Measures:	0180-0180-0275	0380-0380-0575	
Gross Weight (kg):	0.70	7.40	-
CTN 40':	5.395,00		

OBSERVATIONS
