

TECHNICAL DATA 450206101

LAMP INFO	
Description:	FL JULIETTE W latón mate + nogal 1xE27
Mark:	20000 FL Floor Lamp
Reference:	450206101
Range:	58060 JULIETTE
Code EAN:	8421797502065
Measures (mm):	0270-0270-1421
Weight (kg):	4.10

Lampholder/Watts:	E27 LED max.20W	CCT:	-	Switch:	Foot switch
Bulb included:	No	Lm:	-	USB_C:	No
Class:	Class II	Effi LS:	-	Shade:	No
IP:	20	CRI:	-	Dimmable:	No
Driver inc.:	No	Lamp Power:	-		
Voltage/Frequence:	230V - 50Hz	Applied Standard:	CE / LVD		

PACKAGING DETAILS			
	Individual Box	Outer Box	Master Box
Type:	MDC - BROWN PRINTED	MDC - MARRON / BROWN	
Units:	1.00	2.00	0.00
Measures:	0975-0335-0110	0350-0240-0995	
Gross Weight (kg):	5.20	11.70	-
CTN 40':	1.340,00		

OBSERVATIONS

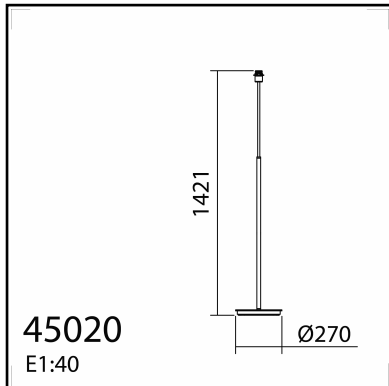

TECHNICAL DATA 450209101

LAMP INFO	
Description:	FL JULIETTE W negro + natural 1xE27
Mark:	20000 FL Floor Lamp
Reference:	450209101
Range:	58060 JULIETTE
Code EAN:	8421797502096
Measures (mm):	0270-0270-1421
Weight (kg):	4.10

Lampholder/Watts:	E27 LED max.20W	CCT:	-	Switch:	Foot switch
Bulb included:	No	Lm:	-	USB_C:	No
Class:	Class II	Effi LS:	-	Shade:	No
IP:	20	CRI:	-	Dimmable:	No
Driver inc.:	No	Lamp Power:	-		
Voltage/Frequence:	230V - 50Hz	Applied Standard:	CE / LVD		

PACKAGING DETAILS			
	Individual Box	Outer Box	Master Box
Type:	MDC - BROWN PRINTED	MDC - MARRON / BROWN	
Units:	1.00	2.00	0.00
Measures:	0975-0335-0110	0350-0240-0995	
Gross Weight (kg):	5.20	11.70	-
CTN 40':	1.340,00		

OBSERVATIONS
